



IMPORTADO POR: SAMSUNG ELECTRONICS MÉXICO. S.A. de C.V.
Vía Lopez Portillo No. 6,
Col. San Fco. Chilpan
Tultitlán, Estado de México, C.P. 54940
TEL. 01-55-5747-5100 / 01-800-726-7864

EXPORTADO POR: Samsung Electronics CO.,LTD.
416, Mae tan-3dong, Yeongtong - gu,
Suwon City, Gyeonggi-do Korea



LN32R51B

TFT-LCD TELEVISION



Owner's Instructions

This device is a Class B digital apparatus.
Register your product at www.samsung.com/global/register

Precautions When Displaying a Still Image

A still image may cause permanent damage to the TV screen.

- Do not display a still image on the LCD panel for more than 2 hours as it can cause screen image retention. This image retention is also known as "screen burn". To avoid such image retention, reduce the degree of brightness and contrast of the screen when displaying a still image.
-  Watching the LCD TV in 4:3 format for a long period of time may leave traces of borders displayed on the left, right and center of the screen caused by the difference of light emission on the screen. Playing a DVD or a game console may cause a similar effect to the screen. Damages caused by the above effect are not covered by the Warranty.
- Displaying still images from Video games and PC for longer than a certain period of time may produce partial after-images. To prevent this effect, reduce the 'brightness' and 'contrast' when displaying still images.

Chapter 1: General Information	
List of Features	1
List of Parts	1
Familiarizing Yourself with Your New TV	2
Buttons on the Lower-Right Part of the Panel	2
Rear Panel Jacks	3
Remote Control	4
Installing Batteries in the Remote Control	6
If the remote control doesn't work	6
 Chapter 2: Connections	
Connecting VHF and UHF Antennas	7
Antennas with 300-ohm Flat Twin Leads	7
Antennas with 75-ohm Round Leads	8
Separate VHF and UHF Antennas	8
Connecting Cable TV	8
Cable without a Cable Box	8
Connecting to a Cable Box that Descrambles All Channels	9
Connecting to a Cable Box that Descrambles Some Channels	9
Connecting a VCR	11
Connecting an S-VHS VCR	12
Connecting a Camcorder	13
Connecting a DVD Player	14
Connecting a Digital TV Set-top box	15
Connecting an Amplifier/DVD Home Theater	15
Connecting a DVD/Set-top box via DVI	16
Connecting a DVD/Set-top box via HDMI	17
Connecting a PC	18
 Chapter 3: Operation	
Turning the TV On and Off	19
Changing Channels	19
Using the Channel Buttons	19
Using the Number Buttons	19
Using the PRE-CH Button to select the Previous Channel	19
Adjusting the Volume	20
Using Mute	20
Viewing the Display	21
Viewing the Menu	21
Plug & Play Feature	22
Memorizing the Channels	24
Selecting the Video Signal-source	24
Storing Channels in Memory (Automatic Method)	25
Adding and Erasing Channels (Manual Method)	26
To Select the Source	27
To Edit the Input Source Name	28
 Chapter 4: Picture Control	
Using Automatic Picture Settings	29
Customizing the Picture	30
Adjusting the Color Tone	31
Changing the Screen Size	32
Zoom	33
Freezing the Picture	34
Digital Noise Reduction	34
DNiE (Digital Natural Image engine)	35

My Color Control	36
Easy Control	36
Detail Control	37
Dynamic Contrast	38
Brightness Sensor	39
Viewing Picture-in-Picture	40
Activating Picture-in-Picture	40
Selecting a Signal Source (External A/V) for PIP	41
Swapping the Contents of the PIP and Main image	41
Changing the PIP Channel	41
Changing the Size of the PIP Window	42
Changing the Position of the PIP Window	42
PIP Settings	42
Chapter 5: Sound Control	
Using Automatic Sound Settings	43
Customizing the Sound	44
Setting the TruSurround XT (SRS TSXT)	45
Choosing a Multi-Channel Sound (MTS) Soundtrack	46
Automatic volume control	47
Selecting the Internal Mute	48
Selecting the Main or Sub (PIP) Sound	49
Chapter 6: Channel Control	
Fine Tuning Channels	50
Chapter 7: PC Display	
Using Your TV as a Computer (PC) Display	51
Setting Up Your PC Software (Based on Windows XP)	51
How to Auto Adjust	52
Adjusting the Screen Quality	53
Changing the Screen Position	54
Initializing the Screen Position or Color Settings	55
Chapter 8: Time Setting	
Setting the Clock	56
Setting the Sleep Timer	57
Setting the On/Off Timer	58
Chapter 9: Function Description	
Selecting a Menu Language	60
Activating the child Lock	61
Viewing Closed Captions	63
Setting the Blue Screen Mode	65
Selecting the Melody	66
Chapter 10: Troubleshooting	
Identifying Problems	67
Appendix	
Installing the stand	69
Disconnecting the stand	69
Installing the Wall Mount Kit	70
Using the Anti-Theft Kensington Lock	71
Using Your TV in Another Country	71
Specifications	72
Display Modes	74

Chapter 1

GENERAL INFORMATION

List of Features

- Excellent Picture Quality
 - DNIe technology provides life-like clear images.
 - My Color Control: Colors can be set to your preference by adjusting pink, blue and green.
 - Dynamic Contrast: Automatically detects the input visual signal and adjusts to create optimum contrast.
 - Brightness Sensor: Adjusts the screen brightness automatically depending on the brightness of the surrounding environment.
- SRS TruSurround XT
 - SRS TruSurround XT provides a virtual Dolby surround system.
- Convenience
 - The TV utilizes the HDMI system to implement perfect digital sound and picture quality.
 - The Anynet system enables you to easily control Samsung audio-video (AV) devices from this TV.

List of Parts

Please make sure the following items are included with your LCD TV.
If any items are missing, contact your dealer.

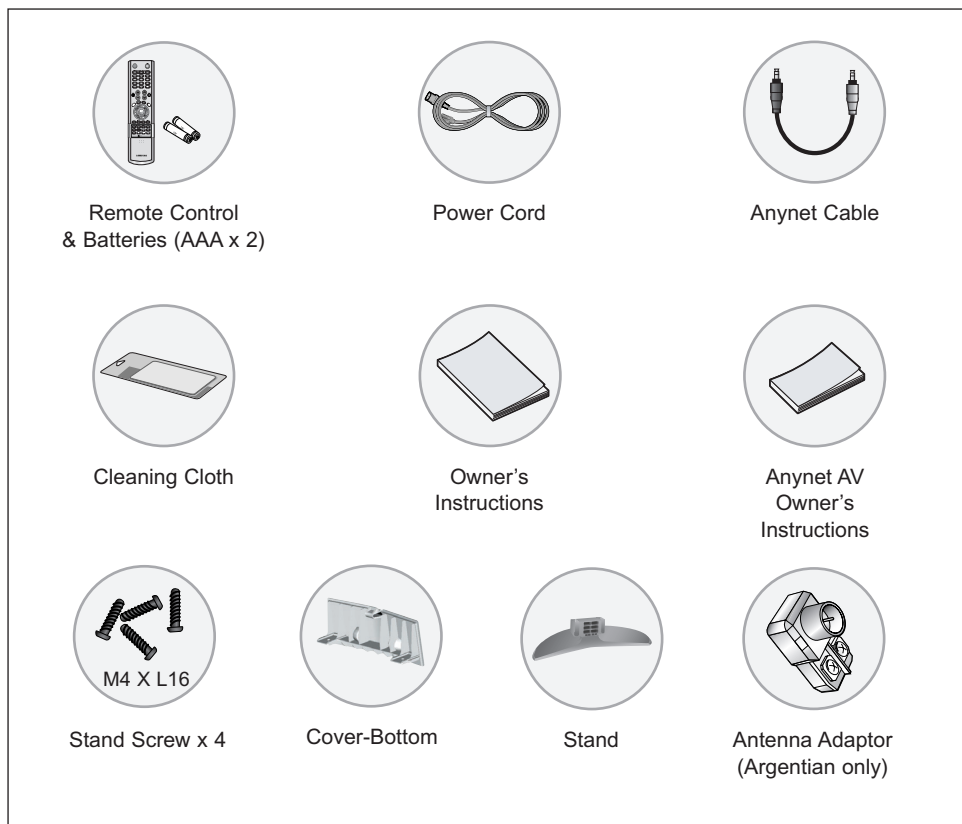



Familiarizing Yourself with Your New TV

Buttons on the Lower-Right Part of the Panel

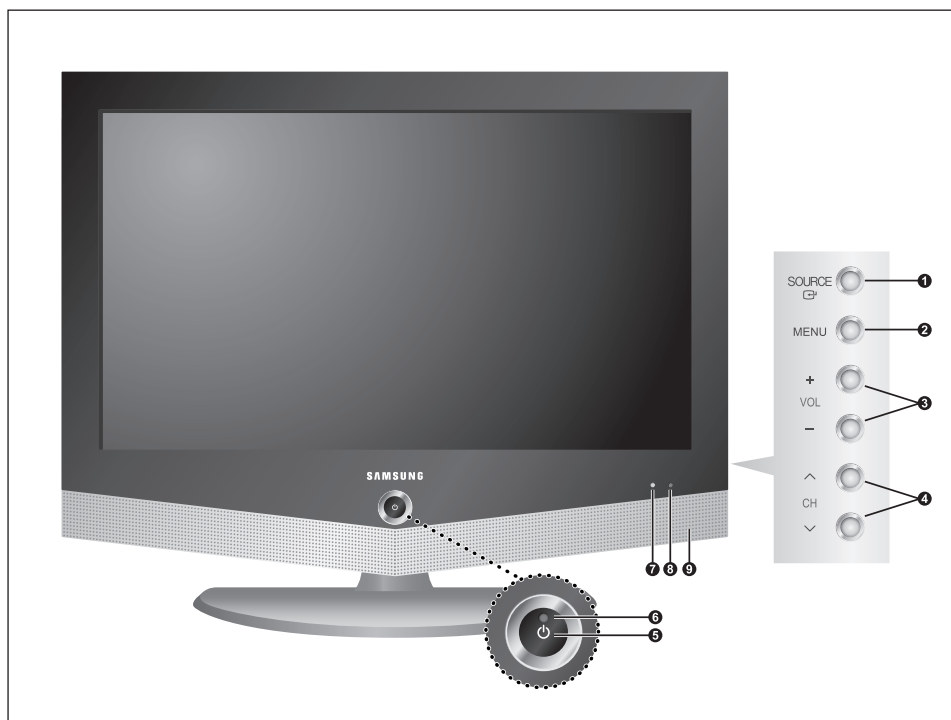
The buttons on the lower-right panel control your TV's basic features, including the on-screen menu. To use the more advanced features, you must use the remote control.



- 1 SOURCE** 

Displays a menu of all of the available input sources (TV, AV1, AV2, S-Video, Component 1, Component 2, PC, HDMI). In the on-screen menu, use this button as you use the **ENTER**  button on the remote control.
- 2 MENU**

Press to see an on-screen menu of your TV's features.
- 3 - VOL +**

Press to decrease or increase the volume. In the on-screen menu, use the - VOL + buttons as you use the **◀** and **▶** buttons on the remote control.
- 4 v CH ^**

Press to change channels. In the on-screen menu, use the v CH ^ buttons as you use the **▼** and **▲** buttons on the remote control. (Without the Remote Control, You can turn on TV by using the Channel buttons.)
- 5  (POWER)**

Press to turn the TV on and off.
- 6 POWER INDICATOR**

Blinks and turns off when the power is on and lights up in stand-by mode.
- 7 LIGHT DETECTING SENSOR**

Adjusts the brightness of the screen automatically by detecting brightness of the surrounding environment. This sensor works when the Brightness Sensor is on.
- 8 REMOTE CONTROL SENSOR**

Aim the remote control towards this spot on the TV.
- 9 SPEAKERS**

GENERAL INFORMATION

Rear Panel Jacks

Use the rear panel jacks to connect an A/V component that will be connected continuously such as a VCR or a DVD player.

For more information on connecting equipment, see pages 7-18.

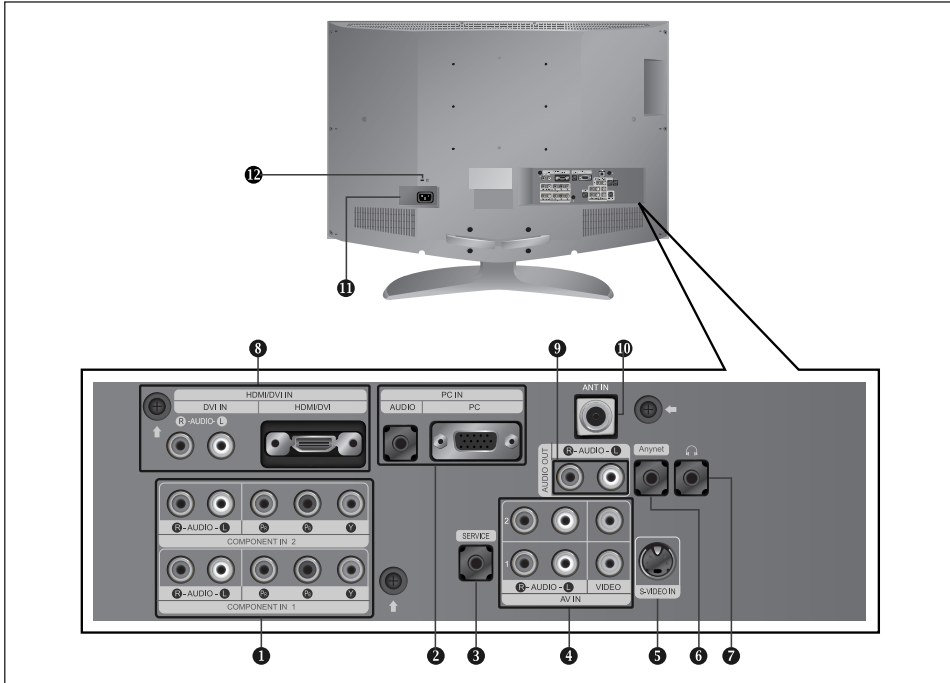

1 COMPONENT IN 1, 2

Connect component video/audio from a DVD/Set-top box.

2 PC IN

Connect to the video and audio output jack on your PC.

3 SERVICE

Connector for service only.

4 AV IN

Video and audio inputs for external devices, such as a camcorder or VCR.

5 S-VIDEO IN

Video inputs for external devices with an S-Video output, such as a camcorder or VCR.

6 Anynet

Refer to "Anynet AV Owner's Instructions".

7 HEADPHONE JACK

Connect a set of external headphones for private listening.

8 HDMI/DVI IN

Connect to the HDMI jack of a device with HDMI output.

Use the HDMI/DVI terminal for DVI connection to an external device. You should use the DVI-to-HDMI cable or DVI-HDMI Adapter for the connection, and the 'R -AUDIO -L' terminal on DVI-IN for sound output. (HDMI/DVI IN terminal does not support PC.)

9 AUDIO OUT

Connect to the audio input jack on your amplifier.

10 ANT IN

Connect to an antenna or to a cable TV system.

11 POWER INPUT

Connect the supplied power cord.

12 KENSINGTON LOCK

Refer to "Using the Anti-Theft Kensington Lock" on page 71.

	Speaker			Audio Out		
	RF	AV, S-Video	Component, PC, HDMI	RF	AV, S-VIDEO	Component, PC, HDMI
Internal Mute Off	Speaker Output	Speaker Output	Speaker Output	Sound Output	Sound Output	Sound Output
Internal Mute On	Mute	Mute	Mute	Sound Output	Sound Output	Sound Output
Video No Signal	Mute	Mute	Mute	Mute	Sound Output	Sound Output

Remote Control

You can use the remote control up to a distance of about 23 feet from the TV.
When using the remote, always point it directly at the TV.

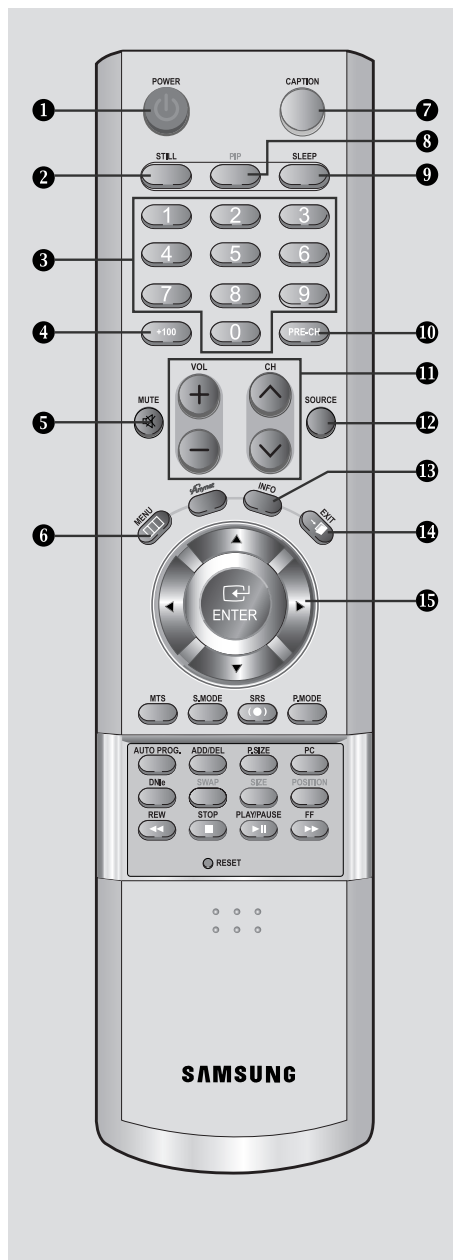

- 1 POWER** Turns the TV on and off. (See page 19)
- 2 STILL** Press to stop the action during a particular scene. Press again to resume normal video. (See page 34)
- 3 NUMBER BUTTONS** Press to change the channel.
- 4 +100** Press to select channels over 100. For example, to select channel 121, press "+100", then press "2" and "1". (See page 19)
- 5 MUTE** Press to temporarily cut off the sound. (See page 20)
- 6 MENU** Displays the main on-screen menu. (See page 21)
- 7 CAPTION** Controls the caption decoder. (See page 63)
- 8 PIP** Picture-in-Picture ON/OFF. (See page 40)
- 9 SLEEP** Press to select a time for the TV to turn off automatically. (See page 57)
- 10 PRE-CH** Tunes to the previous channel. (See page 19)
- 11 CH ^ and CH v (Channel UP/Down)** Press CH ^ or CH v to change channels. (See page 19)
VOL + and VOL -
Press to increase or decrease the volume. (See page 20)
- 12 SOURCE** Press to display all of the available video sources. (See page 27)
- 13 INFO** Use to see information on the current broadcast. (See page 21)
- 14 EXIT** Press to exit the menu.
- 15 UP / DOWN / LEFT / RIGHT / ENTER** Use to select on-screen menu items and change menu values.

GENERAL INFORMATION

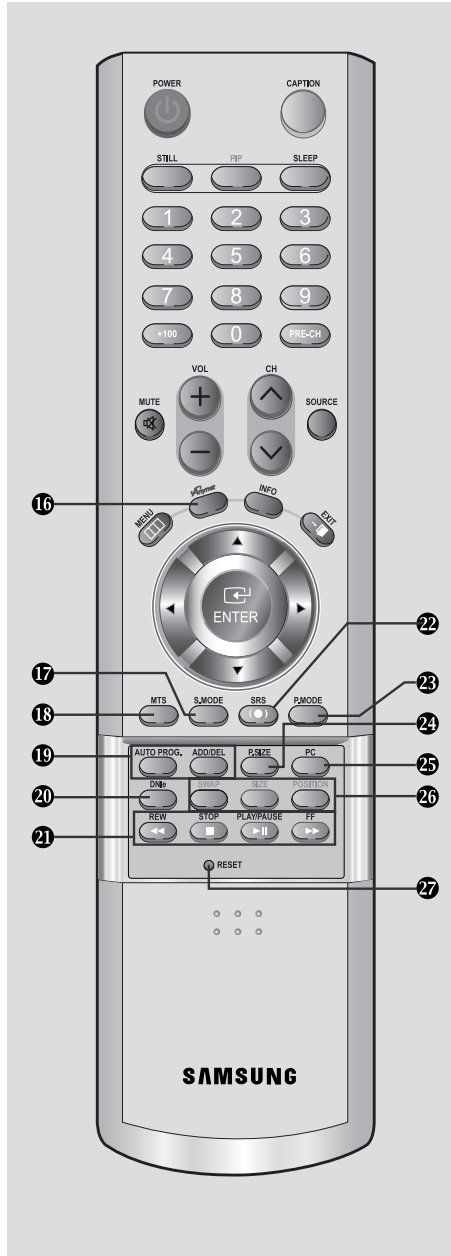

16 Anynet

Press the Anynet button to bring up the Anynet menu. (Refer to "Anynet AV Owner's Instructions".)

17 S.MODE

Adjusts the TV sound by selecting one of the preset factory settings (or selects your personal, customized sound settings). (See page 43)

18 MTS

(Multi channel Television Stereo)

Press to choose stereo, mono or Separate Audio Program (SAP broadcast). (See page 46)

19 AUTO PROG.

Press to automatically store selected TV/Cable channels. (See page 25)

ADD/DEL

Use to store and delete channels to/from memory. (See page 26)

20 DNIe

DNIe Demo On/Off.

Off : DNIe Demo mode is deactivated.

On : The right-hand side of the screen shows the improved DNIe image.

The left-hand side of the screen shows the original image. (See page 35)

21 VCR/DVD Functions (Anynet mode only)

- Rewind
- Stop
- Play/Pause
- Fast Forward

22 SRS

Selects TruSurround XT mode. (See page 45)

23 P.MODE

Adjusts the TV picture by selecting one of the preset factory settings. (See page 29)

24 P.SIZE

Press to change the screen size. (See page 33)

25 PC

Press to switch to the PC mode. (See pages 52-55)

26 SWAP

Press to interchange the main picture and the sub (PIP) picture. (See page 41)

SIZE

Press to make the PIP window small, double1, double2. (See page 42)

POSITION

Press to select the position of sub (PIP) picture. (See page 42)

27 RESET

When your remote does not work, change the batteries and press the RESET button for 2-3 seconds before use.

Installing Batteries in the Remote Control

1

Slide the cover out completely.

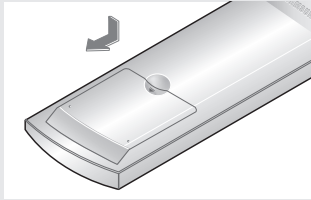

2

Install two AAA size batteries.

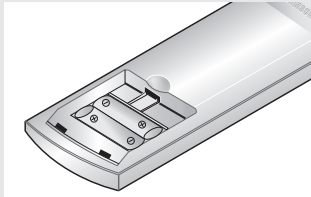

◀ Make sure to match the “+” and “-” ends of the batteries with the diagram inside the compartment.

3

Replace the cover.

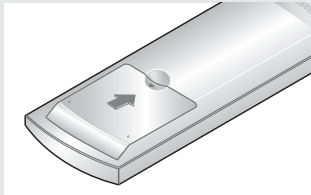

◀ Remove the batteries and store them in a cool, dry place if you won't be using the remote control for a long time.

The remote control can be used up to about 23 feet from the TV. (Assuming typical TV usage, the batteries last for about one year.)

If the remote control doesn't work

Check the following:

1. Is the TV power on?
2. Are the plus and minus ends of the batteries reversed?
3. Are the batteries drained?
4. Is there a power outage, or is the power cord unplugged?
5. Is there a special fluorescent light or a neon sign nearby?

Chapter 2

CONNECTIONS

Connecting VHF and UHF Antennas

If your antenna has a set of leads that look like this, see “Antennas with 300-ohm Flat Twin Leads” below.

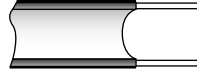

If your antenna has one lead that looks like this, see “Antennas with 75-ohm Round Leads” on the next page.

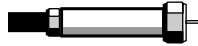

If you have two antennas, see “Separate VHF and UHF Antennas” on the next page.

Antennas with 300-ohm Flat Twin Leads (Argentina only)

- Not available in all locations.

If you are using an off-air antenna (such as a roof antenna or “rabbit ears”) that has 300-ohm twin flat leads, follow the directions below.

1

Place the wires from the twin leads under the screws on a 300-75 ohm adapter (not supplied). Use a screwdriver to tighten the screws.

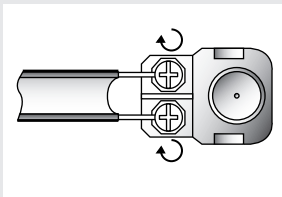

2

Plug the adapter into the ANT IN terminal on the back of the TV.

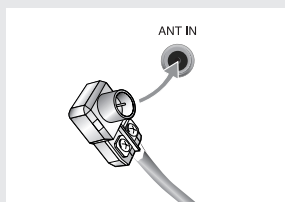

CONNECTIONS

Antennas with 75-ohm Round Leads

1

Plug the antenna lead into the ANT IN terminal on the back of the TV.

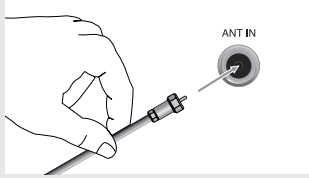

Separate VHF and UHF Antennas

If you have two separate antennas for your TV (one VHF and one UHF), you must combine the two antenna signals before connecting the antennas to the TV. This procedure requires an optional combiner-adapter (available at most electronics shops).

1

Connect both antenna leads to the combiner.

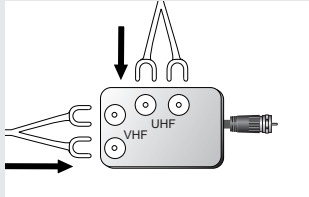

2

Plug the combiner into the ANT IN terminal on the back of the TV.

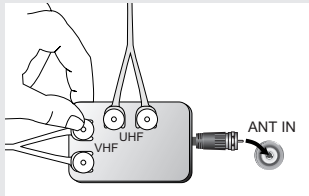

Connecting Cable TV

To connect to a cable TV system, follow the instructions below.

Cable without a Cable Box

1

Plug the incoming cable into the ANT IN terminal on back of the TV.

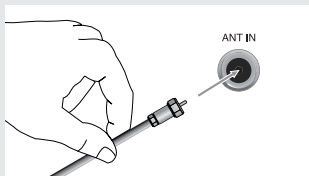

◀ Because this TV is cable-ready, you do not need a cable box to view unscrambled cable channels.

CONNECTIONS

Connecting to a Cable Box that Descrambles All Channels

1

Find the cable that is connected to the ANT OUT terminal on your cable box.

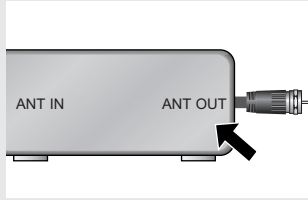

◀ This terminal might be labeled "ANT OUT", "VHF OUT" or simply, "OUT".

2

Connect the other end of this cable to the ANT IN terminal on the back of the TV.

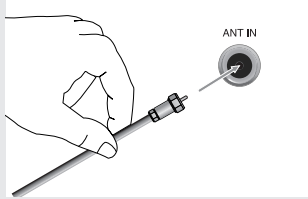

Connecting to a Cable Box that Descrambles Some Channels

If your cable box descrambles only some channels (such as premium channels), follow the instructions below. You will need a two-way splitter, an RF (A/B) switch, and four lengths of RF cable. (These items are available at most electronics stores.)

1

Find and disconnect the cable that is connected to the ANT IN terminal on your cable box.

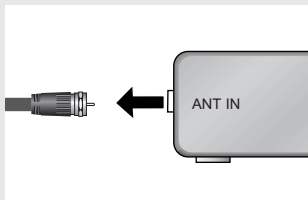

◀ This terminal might be labeled "ANT IN", "VHF IN" or simply, "IN".

2

Connect this cable to a two-way splitter.

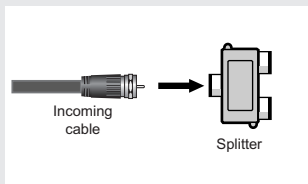

CONNECTIONS

3

Connect an RF cable between an OUTPUT terminal on the splitter and the IN terminal on the cable box.

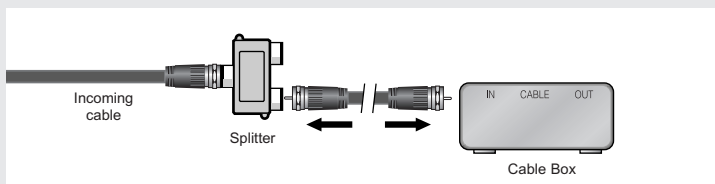

4

Connect an RF cable between the ANT OUT terminal on the cable box and the B-IN terminal on the A/B switch.

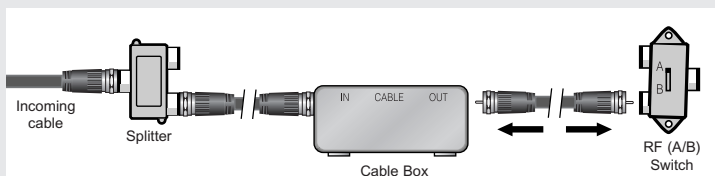

5

Connect another cable between the other OUT terminal on the splitter and the A-IN terminal on the RF (A/B) switch.

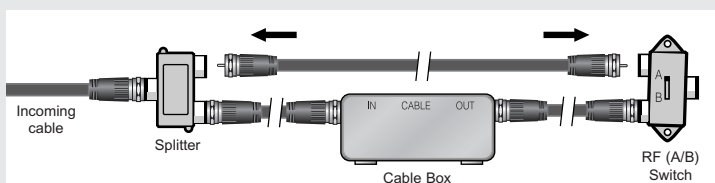

6

Connect the last RF cable between the OUT terminal on the RF (A/B) switch and the ANT IN terminal on the rear of the TV.

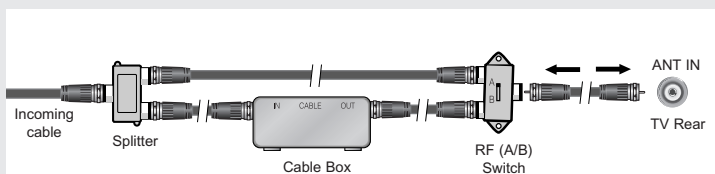

After you've made this connection, set the A/B switch to the "A" position for normal viewing. Set the A/B switch to the "B" position to view scrambled channels. (When you set the A/B switch to "B", you will need to tune your TV to the cable box's output channel, which is usually channel 3 or 4.)

Connecting a VCR

These instructions assume that you have already connected your TV to an antenna or a cable TV system (according to the instructions on pages 7-10).

Skip step 1 if you have not yet connected to an antenna or a cable system.

- 1** Unplug the cable or antenna from the back of the TV.

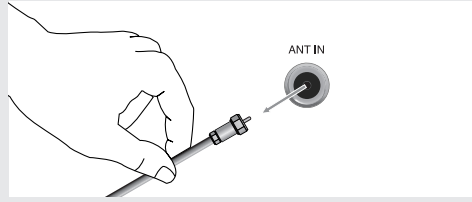

- 2** Connect the cable or antenna to the ANT IN terminal on the back of the VCR.

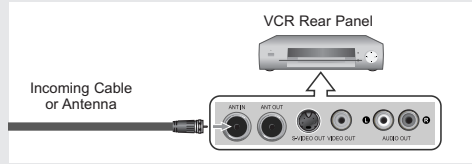

- 3** Connect an RF cable between the ANT OUT terminal on the VCR and the ANT IN terminal on the TV.

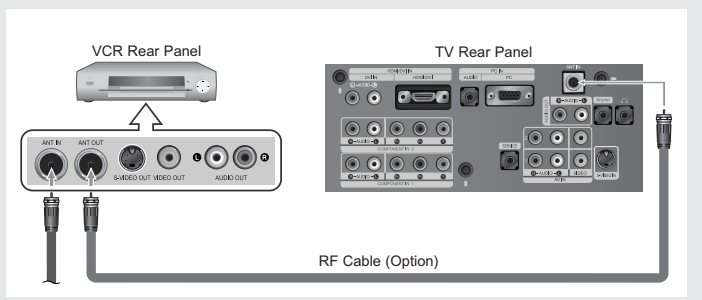

- 4** Connect an audio cable between the AUDIO OUT jacks on the VCR and the AV IN [R-AUDIO-L] jacks on the TV.

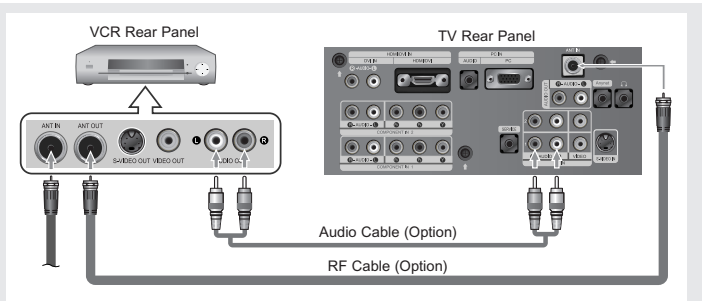

If you have a “mono” (non-stereo) VCR, use the Y-connector (not supplied) to hook up to the left and right audio input jacks of the TV.

- 5** Connect a video cable between the VIDEO OUT jack on the VCR and the AV IN [VIDEO] jack on the TV.

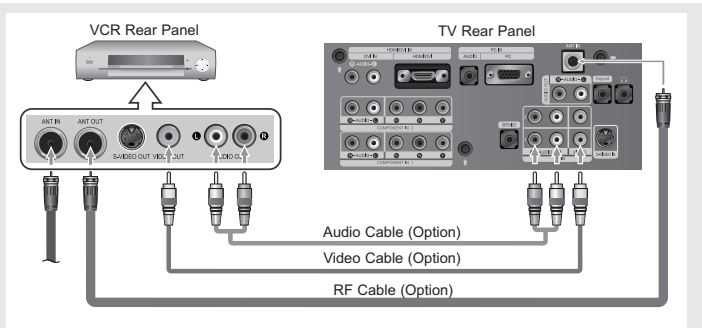

Follow the instructions in “Viewing a VCR or Camcorder Tape” to view your VCR tape.

- * Each external input source device has a different back panel configuration.
- * When connecting an external device, match the color of the connection terminal to the cable.

Connecting an S-VHS VCR

Your Samsung TV can be connected to an S-Video signal from an S-VHS VCR. (This connection delivers a better picture as compared to a standard VHS VCR.)

1

To begin, follow steps 1–3 in the previous section to connect the antenna or cable to your VCR and your TV.

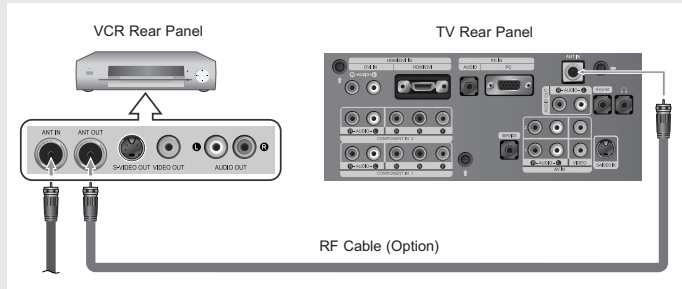

2

Connect an audio cable between the AUDIO OUT jacks on the VCR and the AV IN [R-AUDIO-L] jacks on the TV.

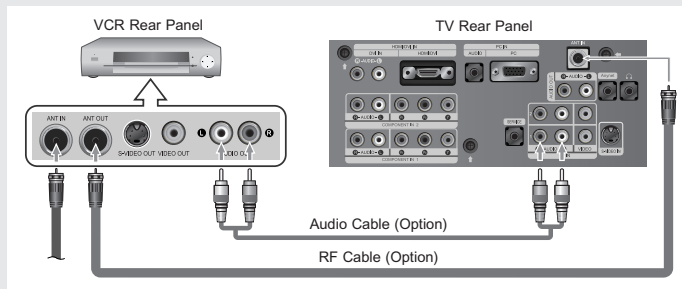

3

Connect an S-Video cable between the S-VIDEO OUT jack on the VCR and the S-VIDEO IN jack on the TV.

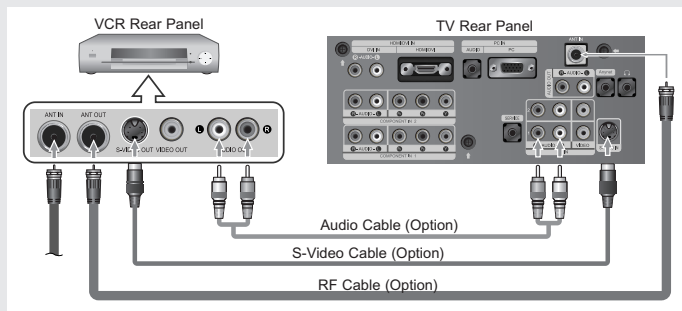

An S-Video cable is usually included with an S-VHS VCR. (If not, check your local electronics store.)

- * Each external input source device has a different back panel configuration.
- * When connecting an external device, match the color of the connection terminal to the cable.

Connecting a Camcorder

The rear panel jacks on your TV make it easy to connect a camcorder to your TV. They allow you to view the camcorder tapes without using a VCR.

1

Connect an audio cable between the AV IN [R-AUDIO-L] jacks on the TV and the AUDIO OUT jacks on the camcorder.

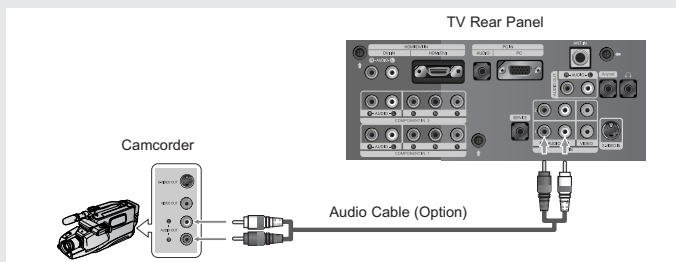

2

Connect a video cable between the AV IN [VIDEO] (or S-VIDEO IN) jacks on the TV and the VIDEO OUT jacks on the camcorder.

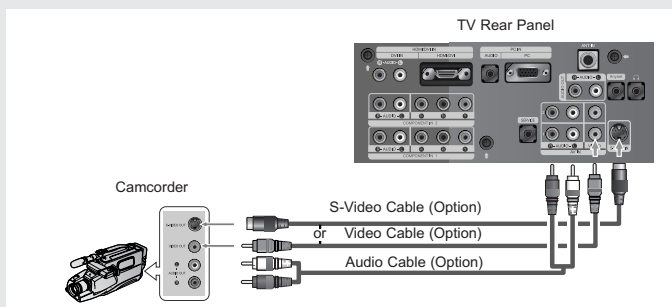

Connecting a DVD Player

The rear panel jacks on your TV make it easy to connect a DVD player to your TV.

1

Connect an audio cable between the COMPONENT IN 1 or COMPONENT IN 2 [R-AUDIO-L] jacks on the TV and the AUDIO OUT jacks on the DVD player.

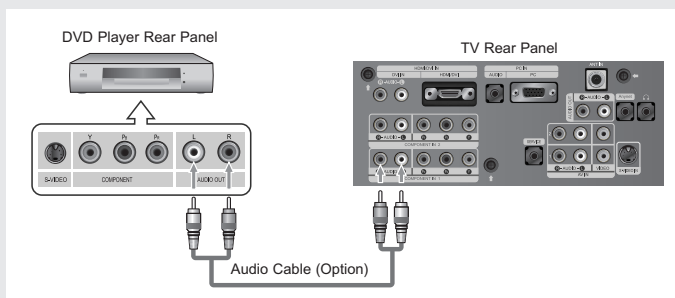

2

Connect a component cable between the COMPONENT IN 1 or COMPONENT IN 2 [P_R, P_B, Y] jacks on the TV and the COMPONENT [Y, P_B, P_R] jacks on the DVD player.

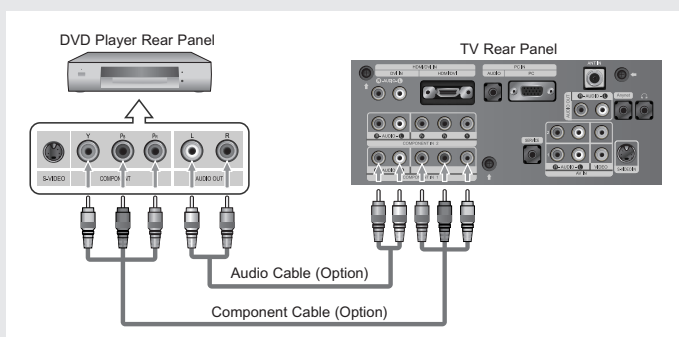

Note: For an explanation of Component video, see your DVD player owner's manual. Be sure to match the component video and audio connections. For example, if connecting the video cable to Component In 1, connect the audio cable to Component In 1 also.

- * Each external input source device has a different back panel configuration.
- * When connecting an external device, match the color of the connection terminal to the cable.

Connecting a Digital TV Set-top box

The connections for a typical Set-top box are shown below.

1

Connect an audio cable between the COMPONENT IN 1 or COMPONENT IN 2 [R-AUDIO-L] jacks on the TV and the AUDIO OUT jacks on the Set-top box.

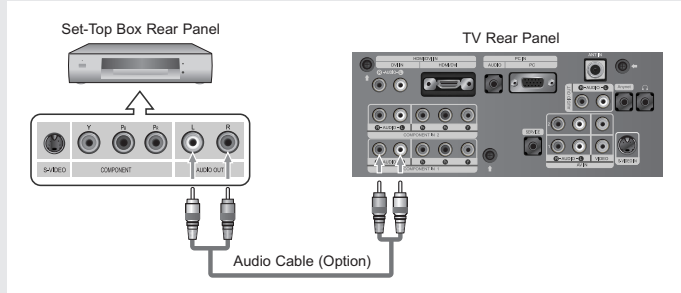

2

Connect a component cable between the COMPONENT IN 1 or COMPONENT IN 2 [P_R, P_B, Y] jacks on the TV and the COMPONENT [Y, P_B, P_R] jacks on the Set-top box.

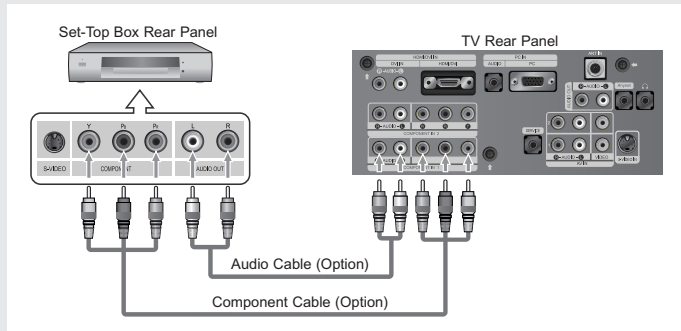

Note: For an explanation of Component video, see your Set-top box owner's manual.

- * Each external input source device has a different back panel configuration.
- * When connecting an external device, match the color of the connection terminal to the cable.

Connecting an Amplifier/DVD Home Theater

1

Connect an audio cable between the AUDIO OUT [R-AUDIO-L] jacks on the TV and the AUDIO IN jacks on the Amplifier/ DVD Home Theater.

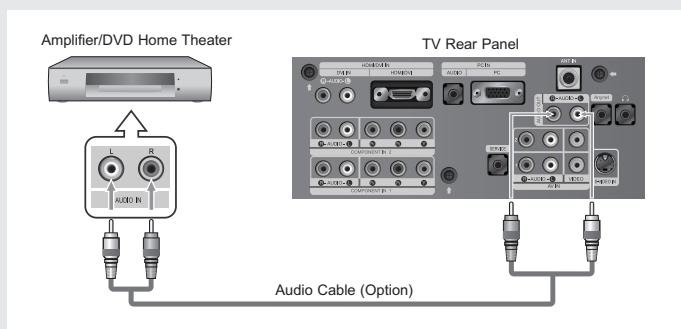

- * When connecting an external device, match the color of the connection terminal to the cable.

Connecting a DVD/Set-top box via DVI

This can be applied only if there is the DVI Output connector on the external device.

1

Connect a DVI-to-HDMI cable or DVI-HDMI adapter between the HDMI/DVI connector on the TV and the DVI connector on the DVD player/Set-top box.

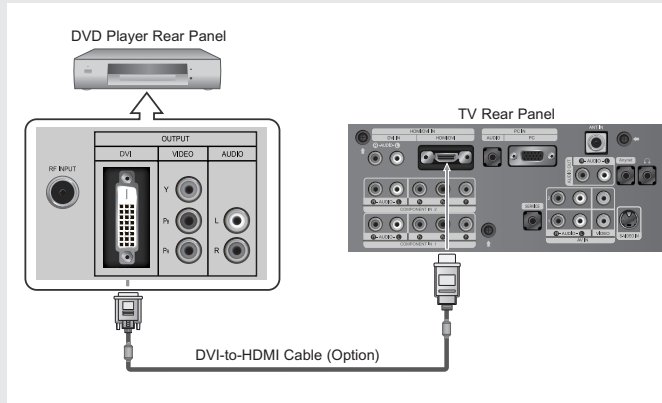

2

Connect an audio cable between the DVI IN [R-AUDIO-L] jack on the TV and the AUDIO OUT jacks on the DVD player/Set-top box.

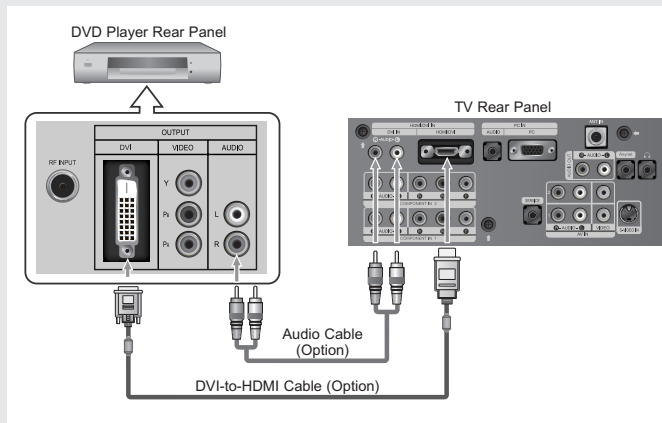

* When connecting an external device, match the color of the connection terminal to the cable.

Connecting a DVD/Set-top box via HDMI

This can be applied only if there is the HDMI Output connector on the external device.

1

Connect an HDMI cable between the HDMI/DVI connector on the TV and the HDMI connector on the DVD player/Set-top box.

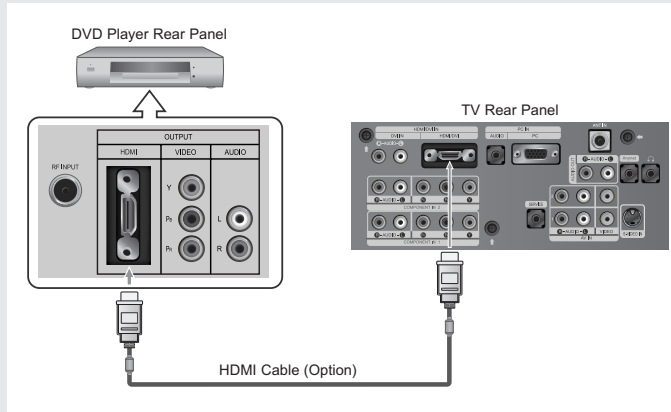

Note: No sound connection is needed for an HDMI to HDMI connection.

What is HDMI?

- HDMI, or high-definition multimedia interface, is a next-generation interface that enables the transmission of digital audio and video signals using a single cable without compression.
- “Multimedia interface” is a more accurate name for it especially because it allows multiple channels of digital audio (5.1 channels). The difference between HDMI and DVI is that the HDMI device is smaller in size, has the HDCP (High Bandwidth Digital Copy Protection) coding feature installed, and supports multi-channel digital audio.

Connecting a PC

1

Connect a PC video cable(D-Sub) between PC IN [PC] connector on the TV and the PC output connector on your computer.

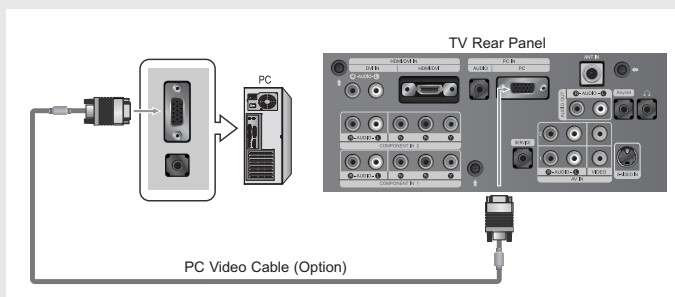

2

Connect a PC audio cable between PC IN [AUDIO] on the TV and the Audio Out of the sound card on your computer.

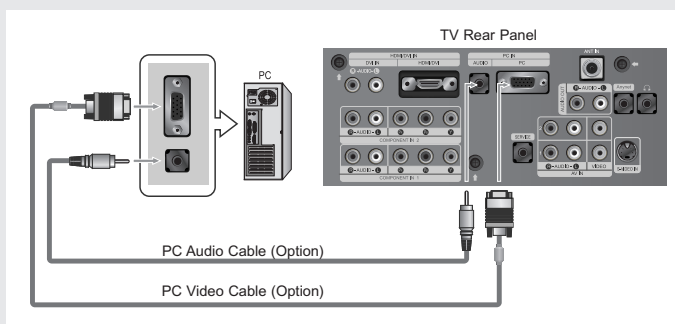



Chapter 3

OPERATION

Turning the TV On and Off

1

Press the **POWER**  button on the remote.
You can also use the **POWER**  button on the front of the panel.

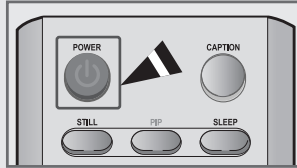



Changing Channels

Using the Channel Buttons

1

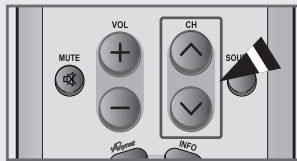



Press the **CH** / buttons to change channels.



When you press the **CH** / buttons, the TV changes channels in sequence. You will see all the channels that the TV has memorized. (The TV must have memorized at least three channels). You will not see channels that were either erased or not memorized. See pages 24-25 to memorize channels.

Using the Number Buttons

1

Press the number buttons to go directly to a channel.
ex) To select channel 27, press """.
To select channel 108, press """.

When you use the number buttons, you can directly select channels that were either erased or not memorized. To change to single-digit channels (0~9) faster, press "0" before the single digit. (For channel "4" press "0", then "4".)

Using the PRE-CH Button to select the Previous Channel

1

Press the **PRE-CH** button.
The TV will switch to the last channel viewed.

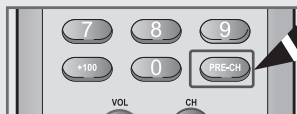

To quickly switch between two channels that are far apart, tune to one channel, then use the number button to select the second channel. Then use the PRE-CH button to quickly alternate between them.

Adjusting the Volume

1

Press the **VOL +** and **VOL –** buttons to increase or decrease the volume.

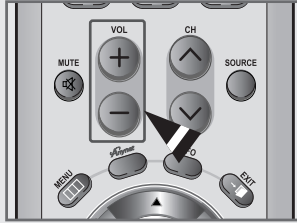

Using Mute

At any time, you can temporarily cut off the sound using the **MUTE** button.

1

Press **MUTE** and the sound cuts off. The word “ Mute” will appear in the lower-left corner of the screen.

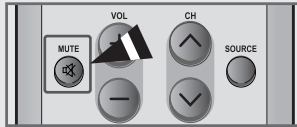

2

To turn mute off, press the **MUTE** button again, or simply press the **VOL +** and **VOL –** buttons.

Viewing the Display

The display identifies the current channel and the status of certain audio-video settings.

1

Press the **INFO** button on the remote control.

The TV will display the channel, the type of sound, and the status of certain picture and sound settings.

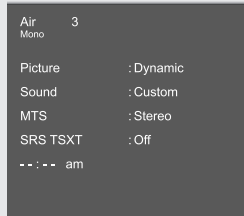

- ◀ Press the **INFO** button once more or wait approximately 10 seconds and it disappears automatically.
- ◀ Allows the user to adjust the settings according to his/her preference and shows the current settings.

Viewing the Menus

1

With the power on, press the **MENU** button.

The main menu appears on the screen.

It's left side has five icons: Input, Picture, Sound, Channel, Setup.

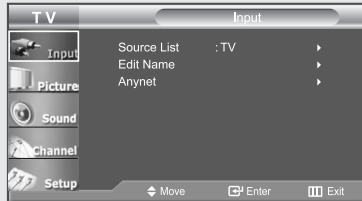

- ◀ The on-screen menus disappear from the screen after about two minutes.

2

Use the **UP/DOWN** buttons to select one of the 5 icons. Then press the **ENTER** button to access the icon's sub-menu.

3

Press the **EXIT** button to exit.

Plug & Play Feature

When the TV is initially powered on, several basic customer settings proceed automatically and subsequently.

1

Press the **POWER** button on the remote control.

The message "Start Plug & Play" is displayed with "OK" selected.



2

Select the appropriate language by pressing the **UP/DOWN** buttons.

Press the **ENTER** button to confirm your choice.



3

The message "Check antenna input." is displayed with "OK" selected.

Press the **ENTER** button.



4

Press the **UP/DOWN** buttons to select "Air" or "STD" then press the **ENTER** button.

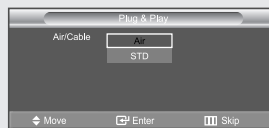

OPERATION

5

Press the **ENTER**  button to select "Start".

The TV will begin memorizing all of the available channels.



◀ To stop the search before it has finished, press the **ENTER**  button with "Stop" selected.

6

Press the **ENTER**  button.

Press the **LEFT/RIGHT**  buttons to move to the "Hour", "Minute" or "am/pm".

Set the "Hour", "Minute" or "am/pm" by pressing the **UP/DOWN**  buttons. (Refer to "Setting the Clock" on page 56.)

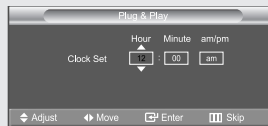
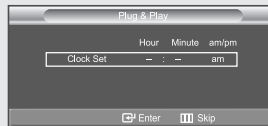

7

Press the **MENU**  button to confirm your setting.

The message "Enjoy your watching." is displayed.

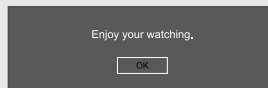

Memorizing the Channels

Your TV can memorize and store all of the available channels for both “off-air” (antenna) and cable channels. After the available channels are memorized, use the CH \wedge and CH \vee buttons to scan through the channels. This eliminates the need to change channels by entering the channel digits. There are three steps for memorizing channels: selecting a broadcast source, memorizing the channels (automatic) and adding and deleting channels (manual).

Selecting the Video Signal-source

Before your television can begin memorizing the available channels, you must specify the type of signal source that is connected to the TV (i.e. an antenna or a cable system).

1

Press the **MENU** \square button to display the menu.

Press the **UP/DOWN** $\blacktriangle/\blacktriangledown$ buttons to select “Channel”, then press the **ENTER** \square button.



2

Press the **ENTER** \square button.

Repeatedly press the **UP/DOWN** $\blacktriangle/\blacktriangledown$ buttons to cycle through these choices: “Air” or “STD” (all cable TV). Press the **EXIT** button to exit.

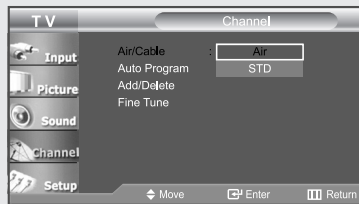

Note: At this point, the signal source has been selected.

Proceed to “Storing Channels in Memory” (next page).

Storing Channels in Memory (Automatic Method)

1

First, select the correct signal source (Air or STD). See steps 1~2 on the previous page.



2

Press the **UP/DOWN ▲▼** buttons to select "Auto Program".

Press the **ENTER** button.

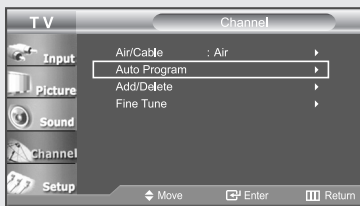

3

Press the **ENTER** button to select "Start". The TV will begin memorizing all of the available channels.

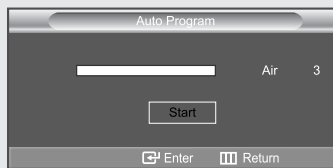

◀ The TV automatically cycles through all of the available channels and stores them in memory. This takes about one to two minutes. Press the **ENTER** button at any time to interrupt the memorization process and return to the "Channel" menu.

4

After all the available channels are stored, the "Channel" menu reappears.

Press the **EXIT** button to exit.

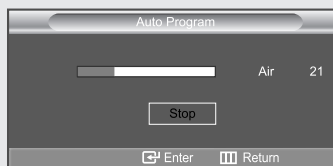

◀ To stop the search before it has finished, press the **ENTER** button with "Stop" selected.

Alternate method:



Press the **AUTO PROG.** button under the remote's cover.





Adding and Erasing Channels (Manual Method)



1



Press the **MENU**  button to display the menu.

Press the **UP/DOWN**   buttons to select "Channel", then press the **ENTER**  button.

Press the **UP/DOWN**   buttons to select "Add/Delete".

Press the **ENTER**  button.

Press the **CH**  or **CH**  button to select channel that you wish to add or delete.

Press the **ENTER**  button to select "Add" or "Delete" (Pressing the **ENTER**  button toggles between the two).

Press the **EXIT** button to exit.

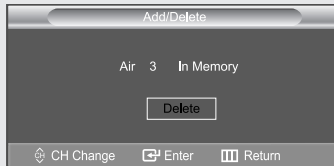

Alternate method:

Use the number buttons to directly select the channel that will be added or erased. Press the **ADD/DEL** button under the remote's cover.

Repeatedly pressing the **ENTER**  button will alternate between "Add" and "Delete". Press the **EXIT** button to exit.

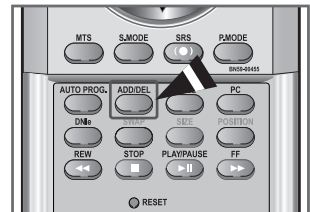



You can view any channel (including an erased channel) by using the number buttons on the remote control.

To Select the Source

Use to select TV or another external input source connected to the TV.
Use to select the input source of your choice.

1

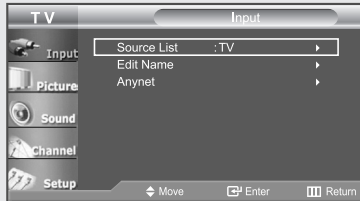

Press the **MENU**  button to display the menu.

Press the **ENTER**  button to select "Input".



2

Press the **ENTER**  button.

Press the **UP/DOWN**  buttons to select the Input source, then press the **ENTER**  button.



Alternate method:

Press the **SOURCE** button on the remote control to view an external signal source.



To Edit the Input Source Name

Name the device connected to the input jacks to make your input source selection easier.

1

Press the **MENU** button to display the menu.

Press the **ENTER** button to select "Input".

Press the **UP/DOWN** buttons to select "Edit Name", then press the **ENTER** button.

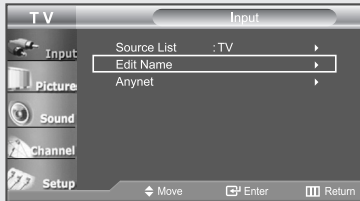
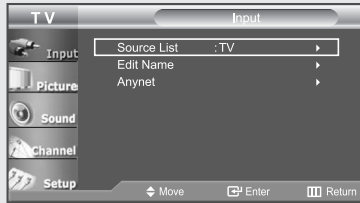

2

Press the **UP/DOWN** buttons to select "AV1", "AV2", "S-Video", "Component1", "Component2", "PC", or "HDMI" input jack, then press the **ENTER** button.



3

Press the **UP/DOWN** buttons to select "VCR", "DVD", "D-VHS", "Cable STB", "HD STB", "Satellite STB", "AV Receiver", "DVD Receiver", "Game", "Camcorder", "DVD Combo", "DHR (DVD HDD Recoder)", or "PC" input source, then press the **ENTER** button.

Press the **EXIT** button to exit.

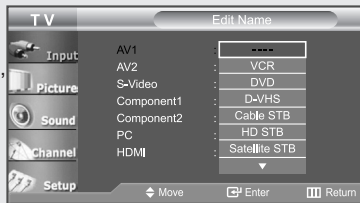

Chapter 4



PICTURE CONTROL

Using Automatic Picture Settings

Your TV has four automatic picture settings (“Dynamic”, “Standard”, “Movie”, and “Custom”) that are preset at the factory. You can activate either Dynamic, Standard, Movie, or Custom by pressing P.MODE (or by making a selection from the menu). Or, you can select “Custom” which automatically recalls your personalized picture settings.

1

Press the **MENU**  button to display the menu.

Press the **UP/DOWN**  buttons to select “Picture”, then press the **ENTER**  button.

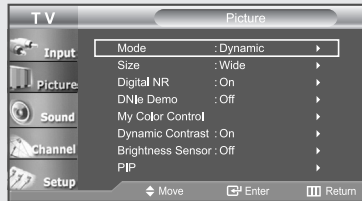

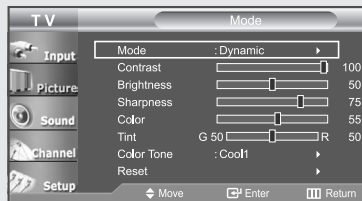

2

Press the **ENTER**  button.



3

Press the **ENTER**  button again to select “Mode”.

Press the **UP/DOWN**  buttons to select “Dynamic”, “Standard”, “Movie”, or Custom”.

Press the **ENTER**  button.

Press the **EXIT** button to exit.

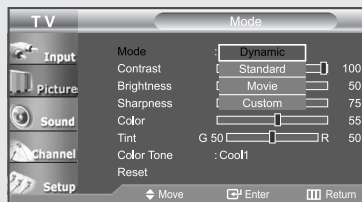

Alternate method:

Simply press the **P.MODE** button on the remote control to select one of the standard picture settings.

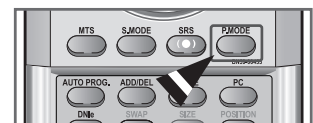

- Choose *Dynamic* to increase the clarity and sharpness of the picture.
- Choose *Standard* for the standard factory settings.
- Choose *Movie* when watching movies.
- Choose *Custom* if you want to adjust the settings according to personal preference (see “Customizing the Picture, page 30).

Customizing the Picture

You can use the on-screen menus to change the contrast, brightness, sharpness, color, and tint according to personal preference.
(Alternatively, you can use one of the “automatic” settings. See the previous page.)

1

Press the **MENU** button to display the menu.

Press the **UP/DOWN** buttons to select “Picture”, then press the **ENTER** button.

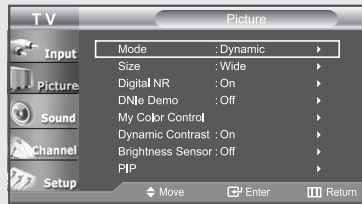

2

Press the **ENTER** button.

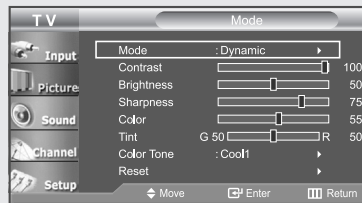

3

Press the **UP/DOWN** button to select a particular item (Contrast, Brightness, Sharpness, Color, or Tint), then press the **ENTER** button.

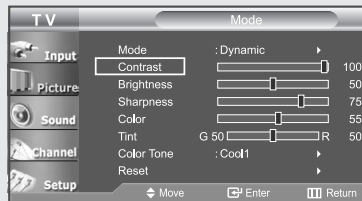

◀ The adjusted values are stored according to the selected Picture mode.

4

Press the **LEFT/RIGHT** buttons to decrease or increase the value of a particular item.

For example, if you select “Contrast”, pressing the **RIGHT** button increases it.

Press the **EXIT** button to exit.



◀ You can select the option (Contrast, Brightness, Sharpness, Color, or Tint) to be adjusted by pressing the **UP/DOWN** button.

Adjusting the Color Tone

You can change the color of the entire screen according to your preference.

1

Press the **MENU** button to display the menu.

Press the **UP/DOWN** buttons to select "Picture", then press the **ENTER** button.

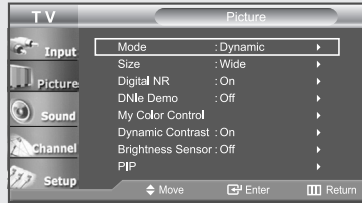

2

Press the **ENTER** button.

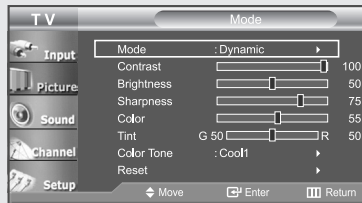

3

Press the **UP/DOWN** button to select "Color Tone", then press the **ENTER** button.

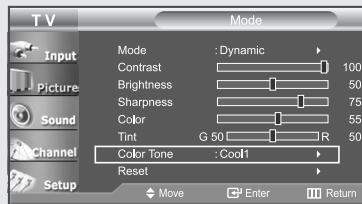

4

Press the **UP/DOWN** buttons to select "Cool2", "Cool1", "Normal", "Warm1", or "Warm2".

Press the **ENTER** button.

Press the **EXIT** button to exit.

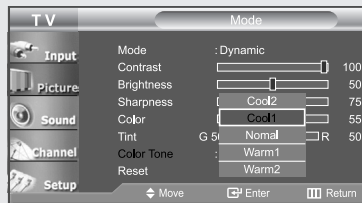

◀ Choose from the following Color Tone settings: "Cool2", "Cool1", "Normal", "Warm1", "Warm2" according to personal preference.

◀ The adjusted values are stored according to the selected Picture mode.

Resetting the Picture Settings to the Factory Defaults

Press the **ENTER** button again to select "Mode".

Press the **UP/DOWN** buttons to select "Reset", then press the **ENTER** button.

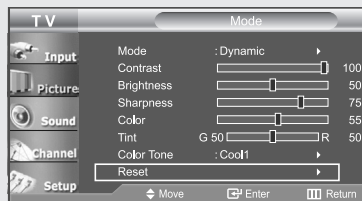

◀ The "Reset" will be set for each picture mode.

Changing the Screen Size

1

Press the **MENU** button to display the menu.

Press the **UP/DOWN** buttons to select "Picture", then press the **ENTER** button.

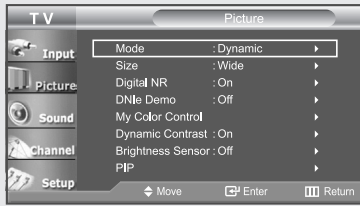

◀ Only the wide and 4:3 sizes can be selected when the Source is PC.

2

Press the **UP/DOWN** buttons to select "Size" then press the **ENTER** button.

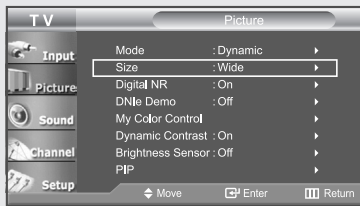

3

Press the **UP/DOWN** buttons to select "Wide", "Zoom" or "4:3".

Press the **EXIT** button to exit.

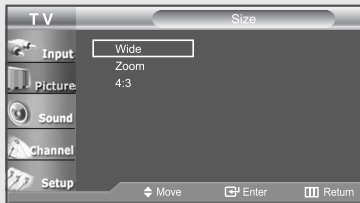

- **Wide** : Sets the picture to 16:9 wide mode.
- **Zoom** : Magnifies the size of the picture on the screen.
 [Positioning and Sizing the screen using Zoom]
 - Resizing the screen using the Zoom enables the positioning and sizing of the screen to up/down direction using the ▲ or ▼ button as well as the screen size.
 - Move the screen up/down using the ▲ or ▼ button after selecting the [Zoom] by pressing the ◀ or ▶ button.
 - Resize the screen vertically using the ▲ or ▼ button after selecting the [Zoom] by pressing the ◀ or ▶ button. (Pressing the ▲ button extends it upward and pressing the ▼ button extends it downward.)
- **4 : 3** : Sets the picture to 4:3 normal mode.
 This is the standard TV screen size.

PICTURE CONTROL

Zoom

1

Press the **UP/DOWN ▲▼** buttons to select "Zoom".

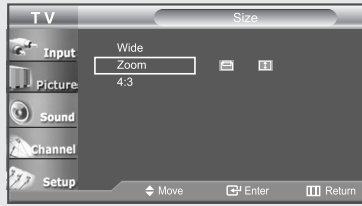

2

Select  by pressing the **LEFT/RIGHT ◀▶** buttons. Use the **UP/DOWN ▲▼** button to move the picture up and down.



3

After selecting , use the **UP/DOWN ▲▼** button to magnify or reduce the picture size in a vertical direction.

Press the **EXIT** button to exit.

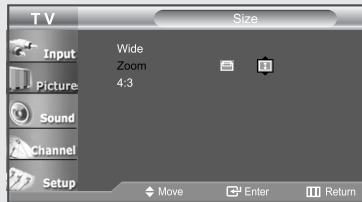

Alternate method:

Press the **P.SIZE** button under the remote's cover to change the screen size.

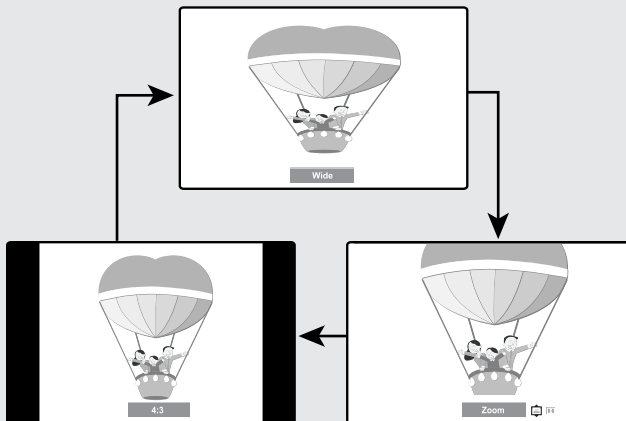
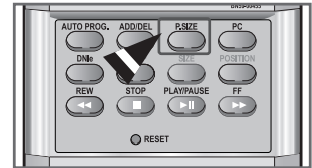

Freezing the Picture



1

Press the **STILL** button to freeze a moving picture.

- Normal sound will still be heard.

Press again to cancel.

Digital Noise Reduction

If the broadcast signal received by your TV is weak, you can activate the Digital Noise Reduction feature to help reduce any static and ghosting that may appear on the screen.

1

Press the **MENU** button to display the menu.

Press the **UP/DOWN** buttons to select "Picture", then press the **ENTER** button.

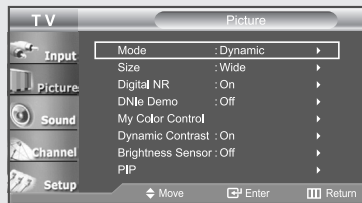

2

Press the **UP/DOWN** buttons to select "Digital NR", then press the **ENTER** button.

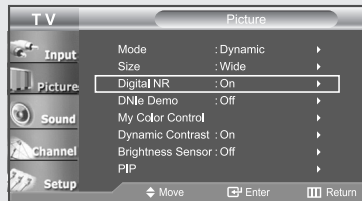

3

Press the **UP/DOWN** buttons to select "Off".

Press the **EXIT** button to exit.

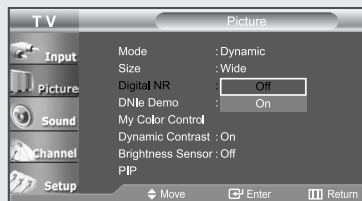

DNle (Digital Natural Image engine)

Samsung's new technology brings you more detailed images with contrast, white enhancement and 3D noise reduction.

You can see how DNle improves the picture by setting DNle demo mode to On.

1

Press the **MENU** button to display the menu.

Press the **UP/DOWN** buttons to select "Picture", then press the **ENTER** button.

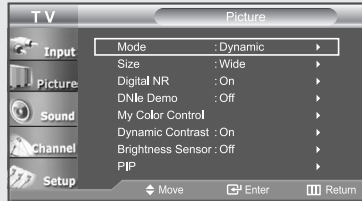

2

Press the **UP/DOWN** buttons to select "DNle Demo", then press the **ENTER** button.

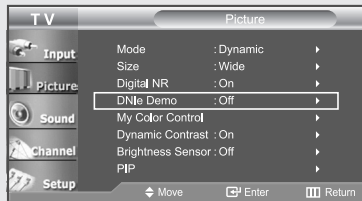

◀ This function doesn't work when Source is in PC mode.

3

Press the **UP/DOWN** buttons to select "On", then press the **ENTER** button.

Press the **EXIT** button to exit.

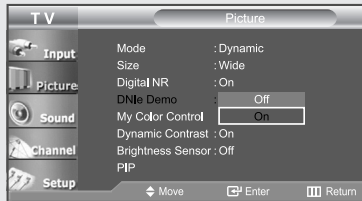

Alternate method:

Press the **DNle** button under the remote's cover to change the DNle Demo mode.



- DNle Demo: Off
DNle Demo mode is deactivated.
- DNle Demo: On
The right-hand side of the screen shows the improved DNle image.
The left-hand side of the screen shows the original image.
- The "DNle Demo" is designed to show the difference between the regular and DNle pictures.
- By default, the product displays the picture with DNle applied.

My Color Control

My Color Control allows users to adjust colors to their preference by adjusting Pink, Blue and Green using the predefined settings (Blue, Green, Pink, Standard, and Custom) without affecting other colors on the screen.

Easy Control

1

Press the **MENU** button to display the menu.

Press the **UP/DOWN** buttons to select "Picture", then press the **ENTER** button.

Press the **UP/DOWN** buttons to select "My Color Control", then press the **ENTER** button.

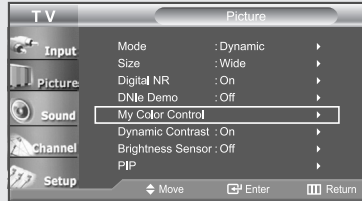
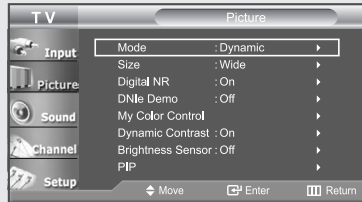

2

Press the **UP/DOWN** buttons to select "Easy Control", then press the **ENTER** button.



◀ This function doesn't work when the Source is in PC mode or PIP is set to on.

3

Press the **LEFT/RIGHT** buttons to select the desired "My Color Control" color, then press the **ENTER** button.

Press the **EXIT** button to exit.

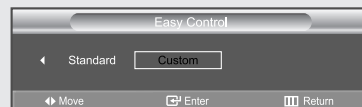

◀ This captures the current screen in a still image to adjust the color.

◀ The Original picture (before adjustment) is shown on the left side, while the selected mode is shown on the right side.



* The sources are displayed in the following order: Blue-Green-Pink-Standard-Custom



PICTURE CONTROL

Detail Control

1



Press the **MENU**  button to display the menu.

Press the **UP/DOWN**  buttons to select "Picture", then press the **ENTER**  button.

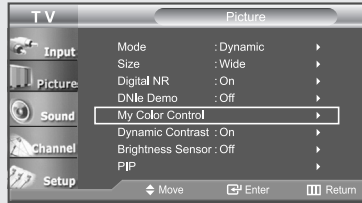
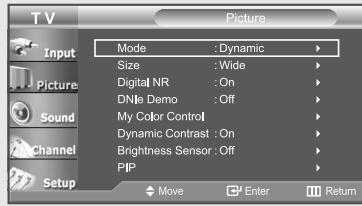
Press the **UP/DOWN**  buttons to select "My Color Control", then press the **ENTER**  button.



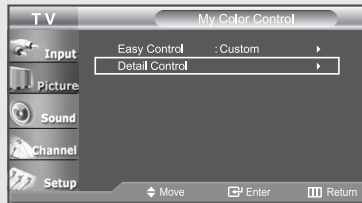

2

Press the **UP/DOWN**  buttons to select "Detail Control", then press the **ENTER**  button.



3

Press the **UP/DOWN**  buttons to select the desired "My Color Control" color, then press the **ENTER**  button.

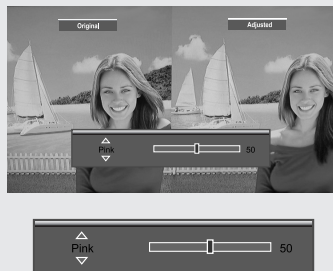
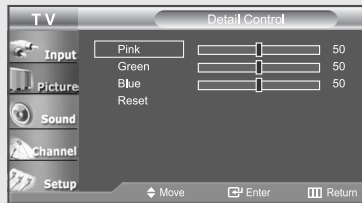

Press the **LEFT/RIGHT**  buttons to increase or decrease the value of a particular item.

Press the **EXIT** button to exit.



◀ This function doesn't work when the Source is in PC mode or PIP is set to on.

◀ This captures the current screen in a still image to adjust the color.

◀ To reset the "Detail Control", select "Reset" by pressing the **UP/DOWN**  button and then press the **ENTER**  button.

* The sources are displayed in the following order: Pink-Green-Blue-Reset

Dynamic Contrast

Dynamic Contrast detects the visual signal input and adjusts to create optimum contrast.

1

Press the **MENU** button to display the menu.

Press the **UP/DOWN** buttons to select "Picture", then press the **ENTER** button.

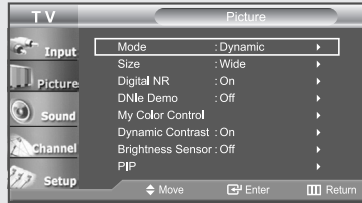

2

Press the **UP/DOWN** buttons to select "Dynamic Contrast", then press the **ENTER** button.

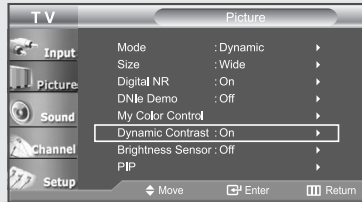

3

Press the **UP/DOWN** buttons to select "Off".

Press the **EXIT** button to exit.

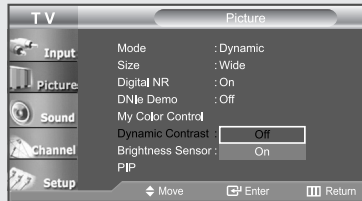





◀ This function doesn't work when the Source is in PC mode or PIP is set to on.

Brightness Sensor

The Brightness Sensor adjusts the screen brightness automatically by using a light detecting sensor.



1

Press the **MENU**  button to display the menu.

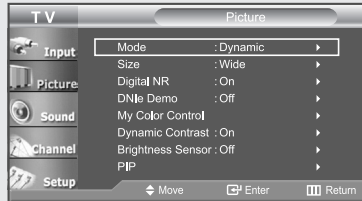
Press the **UP/DOWN**   buttons to select "Picture", then press the **ENTER**  button.



2

Press the **UP/DOWN**   buttons to select "Brightness Sensor", then press the **ENTER**  button.

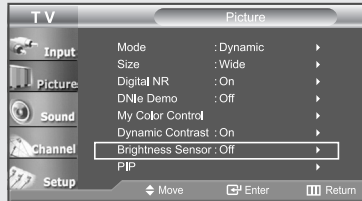

◀ This function doesn't work when the Source is in PC mode.

3

Press the **LEFT/RIGHT**   buttons to select "On".

Press the **EXIT** button to exit.

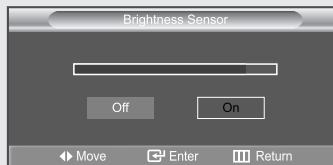
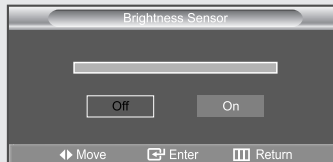

◀ Screen brightness is adjusted automatically depending on the brightness of the surrounding environment.

Viewing Picture-in-Picture



This product has one built-in tuner, which does not allow PIP to function in the same mode. For example, you cannot watch one TV channel in the main screen, and a different one in the PIP screen. Please see 'PIP Settings' below for details.



You can use the PIP feature to simultaneously watch two video sources.

Activating Picture-in-Picture

1

Press the **MENU**  button to display the menu.

Press the **UP/DOWN**  buttons to select "Picture", then press the **ENTER**  button.

Press the **UP/DOWN**  buttons to select "PIP", then press the **ENTER**  button.

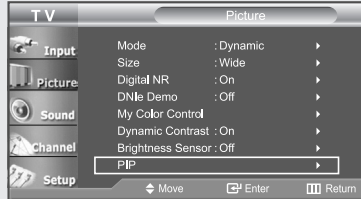

2

Press the **ENTER**  button.

Press the **UP/DOWN**  buttons to select "On".

Press the **ENTER**  button.

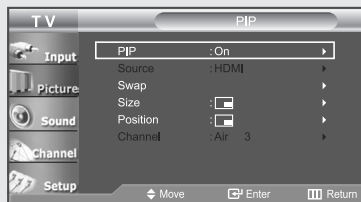
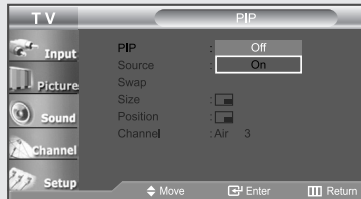

◀ If you turn the TV off while watching in PIP mode and turn it on again, the PIP window will disappear.

Alternate method:

Press the **PIP** button on the remote control repeatedly to activate or deactivate the PIP.

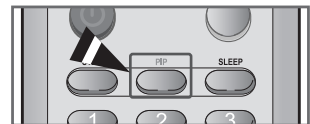

PICTURE CONTROL

Selecting a Signal Source (External A/V) for PIP

3

Press the **UP/DOWN ▲▼** buttons to select "Source", then press the **ENTER** button.

Select the source of the sub picture (PIP) by pressing the **UP/DOWN ▲▼** buttons and press the **ENTER** button.

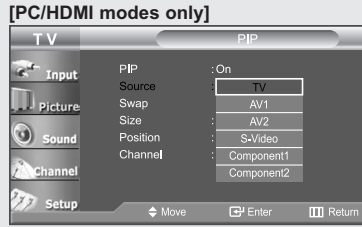

◀ When the main picture is set to TV/ AV1/AV2/S-Video/Component1/ Component2, only HDMI can be selected and when the main picture is set to PC/HDMI, only TV/AV1/ AV2/S-Video/Component1/ Component2 can be selected.

◀ Source selection is possible only when PC or HDMI is connected.

Swapping the Contents of the PIP and Main image

4

Press the **UP/DOWN ▲▼** buttons to select "Swap", then press the **ENTER** button.

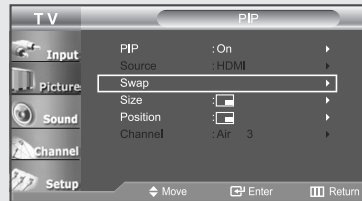

◀ If main picture is in PC Mode, "Swap" is not available.

Alternate method:

Press the **SWAP** button under the remote's cover.



Changing the PIP Channel

5

Press the **UP/DOWN ▲▼** buttons to select "Channel", then press the **ENTER** button.

Press the **UP/DOWN ▲▼** buttons to select the desired channel in the PIP window.

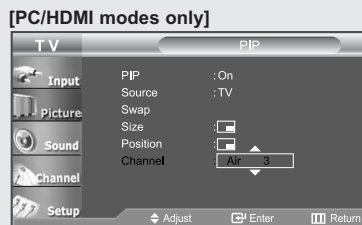

PICTURE CONTROL

Changing the Size of the PIP Window

6

Press the **UP/DOWN ▲▼** buttons to select "Size", then press the **ENTER** button.

Press the **UP/DOWN ▲▼** buttons to select the desired size of the PIP window.

Press the **ENTER** button.

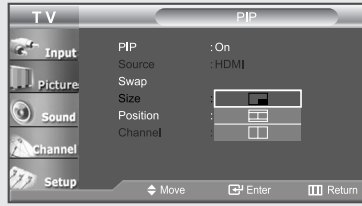

◀ If main picture is in PC Mode, "Size" is not available.

Alternate method:

Press the **SIZE** button under the remote's cover.

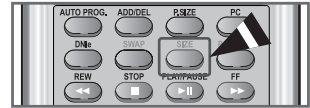

Changing the Position of the PIP Window

7

Press the **UP/DOWN ▲▼** buttons to select "Position", then press the **ENTER** button.

Press the **UP/DOWN ▲▼** buttons to select the desired PIP window position.

Press the **ENTER** button.

Press the **EXIT** button to exit.

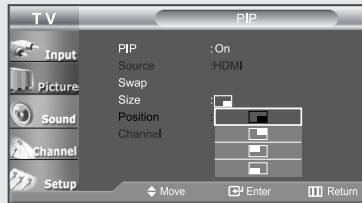

Alternate method:

Press the **POSITION** button under the remote's cover.



PIP Settings

O : PIP operates
X : PIP doesn't operate

Sub Picture Main Picture	TV	AV1	AV2	S-Video	Component1	Component2	PC	HDMI
TV	X	X	X	X	X	X	X	O
AV1	X	X	X	X	X	X	X	O
AV2	X	X	X	X	X	X	X	O
S-Video	X	X	X	X	X	X	X	O
Component1	X	X	X	X	X	X	X	O
Component2	X	X	X	X	X	X	X	O
PC	O	O	O	O	O	O	X	X
HDMI	O	O	O	O	O	O	X	X

- When the PC is in energy saving mode, you cannot choose the PIP option.
- You may notice that the picture in the PIP window becomes slightly unnatural when you use the main screen to view a game or karaoke.
- You can adjust picture position only by using the  size menu.

Chapter 5

SOUND CONTROL

Using Automatic Sound Settings

Your TV has five automatic sound settings (“Standard”, “Music”, “Movie”, “Speech”, and “Custom”) that are preset at the factory. You can activate any of them by pressing the S.MODE button (or by making a selection from the on-screen menu). Or, you can select “Custom”, which automatically recalls your personalized sound settings.

1

Press the **MENU** button to display the menu.

Press the **UP/DOWN** buttons to select “Sound”, then press the **ENTER** button.

Press the **ENTER** button.

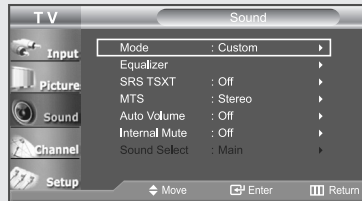

2

Press the **UP/DOWN** buttons repeatedly to select the “Standard”, “Music”, “Movie”, “Speech”, or “Custom” sound settings.

Press the **EXIT** button to exit.

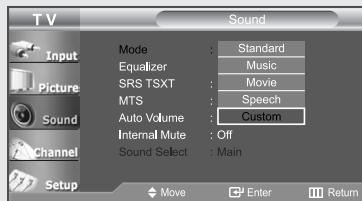

Alternate method:

Simply press the **S.MODE** button on the remote control to select one of the standard sound settings.





- Choose *Standard* for the standard factory settings.
- Choose *Music* when watching music videos or concerts.
- Choose *Movie* when watching movies.
- Choose *Speech* when watching a show that is mostly dialog (i.e. news).
- Choose *Custom* to recall your personalized settings.

Customizing the Sound

The sound settings can be adjusted to suit your personal preference.
(Alternatively, you can use one of the “automatic” settings. See the previous page.)



1

Press the **MENU**  button to display the menu.

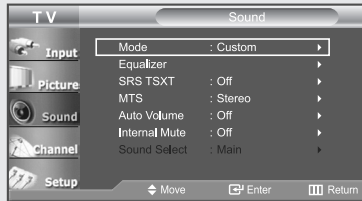
Press the **UP/DOWN**  buttons to select “Sound”, then press the **ENTER**  button.



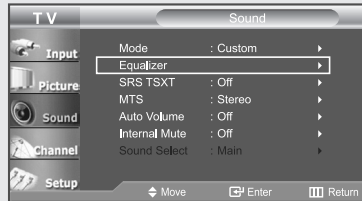

2

Press the **UP/DOWN**  buttons to select “Equalizer”, then press the **ENTER**  button.



3

Press the **LEFT/RIGHT**  buttons to select a particular frequency to be changed.

Press the **UP/DOWN**  buttons to increase or decrease the value of a particular item.

Press the **EXIT** button to exit.

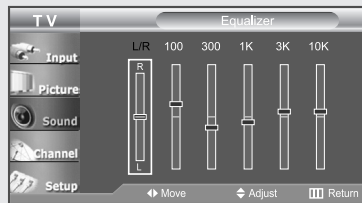

◀ If you make any changes to these settings, the Sound Mode is automatically switched to “Custom”.

Note: The Custom setting allows you to adjust frequencies to your preference.
The lowest frequency is 100 and 10K is the highest.

Setting the TruSurround XT (SRS TSXT)

Emphasizes midrange and bass and provides a simulated surround-sound experience.

1

Press the **MENU** button to display the menu.

Press the **UP/DOWN** buttons to select "Sound", then press the **ENTER** button.

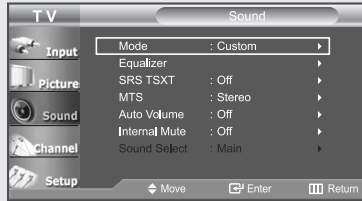

2

Press the **UP/DOWN** buttons to select "SRS TSXT", then press the **ENTER** button.

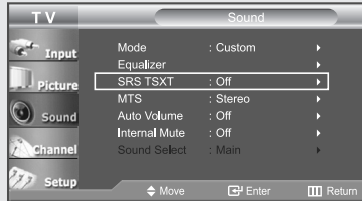

3

Press the **UP/DOWN** buttons to select "Off", "3D Mono" or "Stereo" then Press the **ENTER** button.

Press the **EXIT** button to exit.

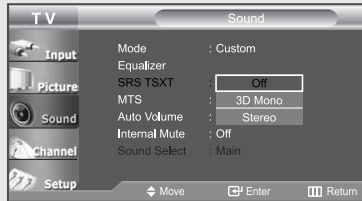

Alternate method:

Simply press the **SRS** button on the remote control to change the "SRS TSXT" settings.



TRADEMARK & LABEL LICENSE NOTICE



TruSurround XT, SRS and  symbol are trademarks of SRS Labs, Inc. TruSurround XT technology is incorporated under license from SRS Labs, Inc.

Choosing a Multi-Channel Sound (MTS) Soundtrack

Depending on the particular program being broadcast, you can listen to stereo, mono or a Separate Audio Program. (SAP audio is usually a foreign-language translation. Sometimes SAP has unrelated information like news or weather).

1

Press the **MENU** button to display the menu.

Press the **UP/DOWN** buttons, then press the **ENTER** button.

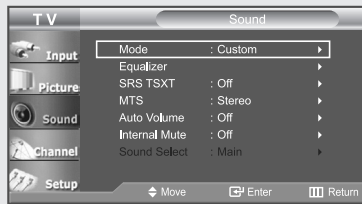

2

Press the **UP/DOWN** buttons to select "MTS", then press the **ENTER** button.

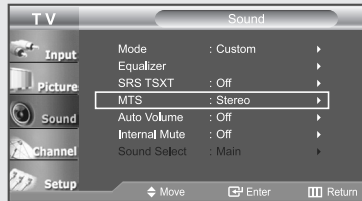

3

Press the **UP/DOWN** buttons to select "Mono", "Stereo" or "SAP", then press the **ENTER** button.

Press the **EXIT** button to exit.

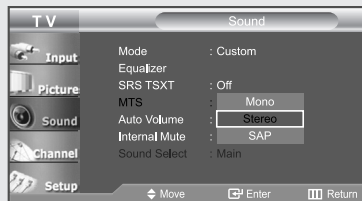

◀ When you change channels, MTS is set to "Stereo" automatically.

Alternate method:

Simply press the **MTS** button on the remote control to change the MTS settings.





- Choose *Mono* for channels that are broadcasting in mono, or if you are having difficulty receiving a stereo signal.
- Choose *Stereo* for channels that are broadcasting in stereo.
- Choose *SAP* to listen to the Separate Audio Program, which is usually a foreign-language translation.

Automatic volume control

Reduces the differences in volume level among broadcasters.



1

Press the **MENU**  button to display the menu.

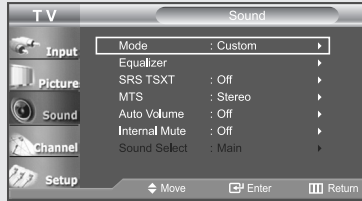
Press the **UP/DOWN**  buttons to select "Sound", then press the **ENTER**  button.



2

Press the **UP/DOWN**  buttons to select "Auto Volume", then press the **ENTER**  button.

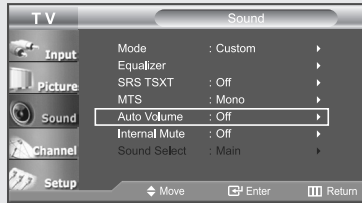

3

Press the **UP/DOWN**  buttons to set Auto Volume "On".

Press the **EXIT** button to exit.

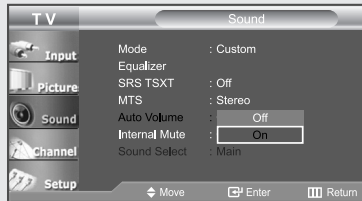



Selecting the Internal Mute

Sound output from the TV speakers is muted.



1

Press the **MENU**  button to display the menu.

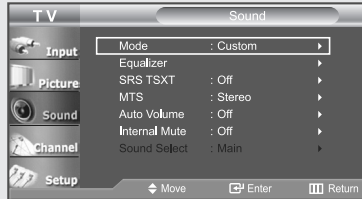
Press the **UP/DOWN**  buttons to select "Sound", then press the **ENTER**  button.



2

Press the **UP/DOWN**  buttons to select "Internal Mute", then press the **ENTER**  button.

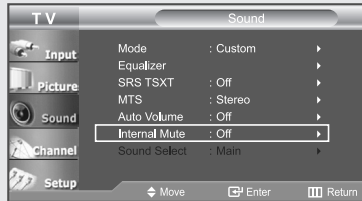

3

Press the **UP/DOWN**  buttons to select "On", Then Press the **ENTER**  button.

Press the **EXIT** button to exit.

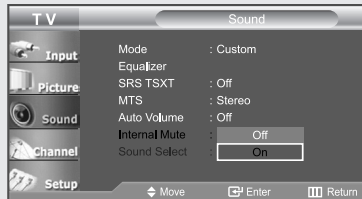

◀ When "Internal mute" is set to "On", Sound menus except "MTS" and "Sound Select" cannot be adjusted.

Selecting the Main or Sub (PIP) Sound

You can select either Main or Sub sound when PIP is On.

1

Press the **MENU** button to display the menu.

Press the **UP/DOWN** buttons to select "Sound", then press the **ENTER** button.

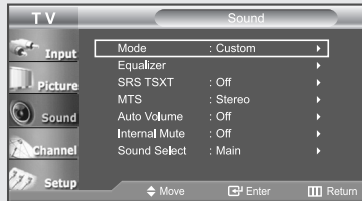

2

Press the **UP/DOWN** buttons to select "Sound Select", then press the **ENTER** button.

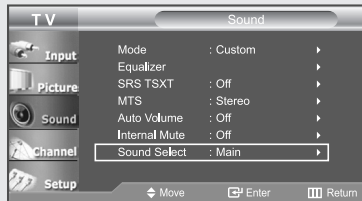

3

Press the **UP/DOWN** buttons to select "Main" or "Sub".

Select "Main" to hear the main TV sound and select "Sub" to hear the PIP window sound.

Press the **EXIT** button to exit.

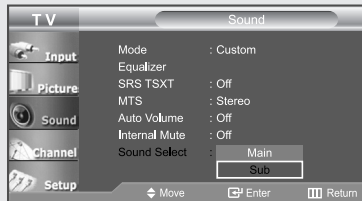

Chapter 6



CHANNEL CONTROL

Fine Tuning Channels

Use fine tuning to manually adjust a particular channel for optimal reception.



1

Press the **MENU**  button to display the menu.

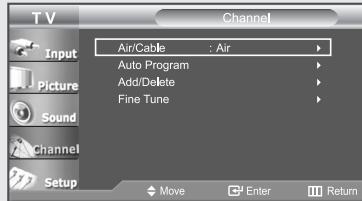
Press the **UP/DOWN**   buttons to select "Channel", then press the **ENTER**  button.



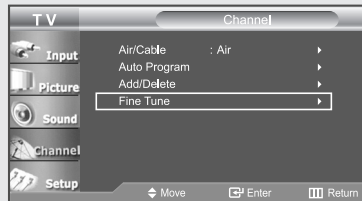

2

Press the **UP/DOWN**   buttons to select "Fine Tune", then press the **ENTER**  button.



3

Press the **LEFT/RIGHT**   buttons to adjust the fine tuning.

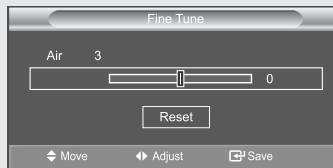

◀ If you do not store the fine-tuned channel in memory, adjustments are not saved.

4

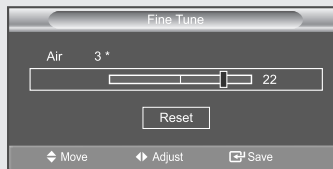

To store the fine tuning setting in the TV's memory, press the **ENTER**  button.

Press the **EXIT** button to exit.

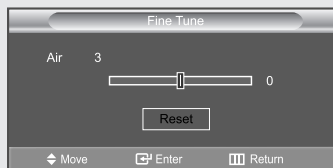

◀ Fine tuned channels that have been saved are marked with an asterisk "*" on the right-hand side of the channel number in the channel banner.



◀ Press the **UP/DOWN**   button to select "Reset", then press the **ENTER**  button.

Chapter 7

PC DISPLAY

Using Your TV as a Computer (PC) Display

Setting Up Your PC Software (Based on Windows XP)

The Windows display-settings for a typical computer are shown below. The actual screens on your PC will probably be different, depending upon your particular version of Windows and your particular video card. However, even if your actual screens look different, the same basic set-up information will apply in almost all cases. (If not, contact your computer manufacturer or Samsung Dealer.)



- 1 First, click on “**Control Panel**” on the Windows start menu.

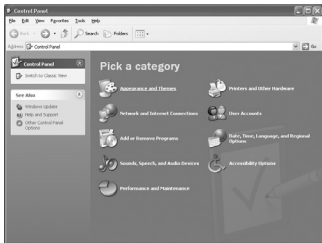

- 2 When the control panel window appears, click on “**Appearance and Themes**” and a display dialog-box will appear.

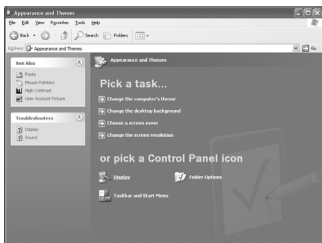

- 3 When the control panel window appears, click on “**Display**” and a display dialog-box will appear.

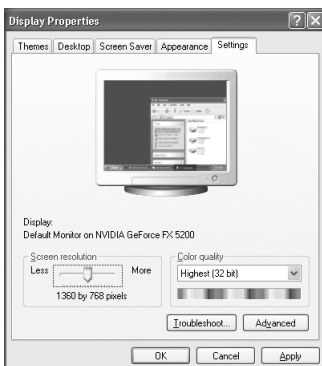

- 4 Navigate to the “**Settings**” tab on the display dialog-box.

The correct size setting (resolution)

-Optimum: 1360 x 768 pixels

If a vertical-frequency option exists on your display settings dialog box, the correct value is “**60**” or “**60 Hz**”. Otherwise, just click “**OK**” and exit the dialog box.

* See “**Display Modes**” on page 74.

How to Auto Adjust

Use the Auto Adjust function to have the TV set automatically adjust the video signals the monitor receives. The function also automatically fine-tunes the settings and adjusts the frequency values and positions.

Press the PC button under the remote's cover to select the PC mode.

1

Press the **MENU** button to display the menu.

Press the **UP/DOWN** buttons to select "Setup", then press the **ENTER** button.

Press the **UP/DOWN** buttons to select "PC", then press the **ENTER** button.



2

Press the **UP/DOWN** buttons to select "Auto Adjustment", then press the **ENTER** button.

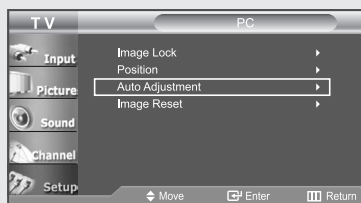

Auto Adjustment in progress.
Please wait.

Adjusting the Screen Quality

The purpose of the picture quality adjustment is to remove or reduce picture noise. If the noise is not removed by fine tuning alone, then do the frequency adjustments to the utmost and fine tune again. After the noise has been reduced, re-adjust the picture so that it is aligned on the center of screen.

Press the **PC** button under the remote's cover to select the **PC** mode.

1

Press the **MENU** button to display the menu.

Press the **UP/DOWN** buttons to select "Setup", then press the **ENTER** button.

Press the **UP/DOWN** buttons to select "PC" then press the **ENTER** button.

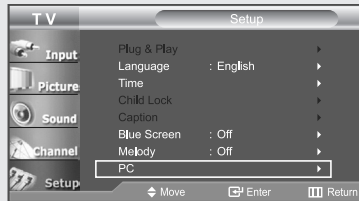
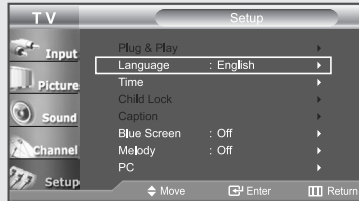

2

Press the **ENTER** button to select "Image Lock".

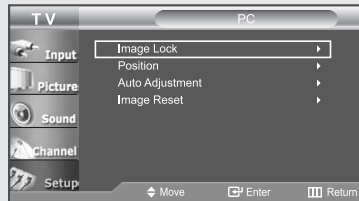

3

Press the **UP/DOWN** buttons to select "Coarse" or "Fine", then press the **ENTER** button.

Press the **LEFT/RIGHT** buttons to adjust the screen quality. Vertical stripes may appear or the picture may be blurry.

Press the **EXIT** button to exit.

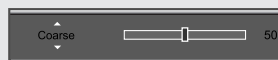
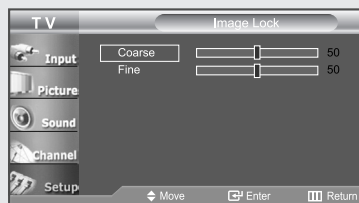

<Adjusting Coarse>

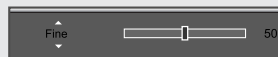



<Adjusting Fine>

Changing the Screen Position

Press the PC button under the remote's cover to select the PC mode.

1



Press the **MENU**  button to display the menu.

Press the **UP/DOWN**  buttons to select "Setup", then press the **ENTER**  button.



2

Press the **UP/DOWN**  buttons to select "PC", then press the **ENTER**  button.

Press the **UP/DOWN**  buttons to select "Position", then press the **ENTER**  button.

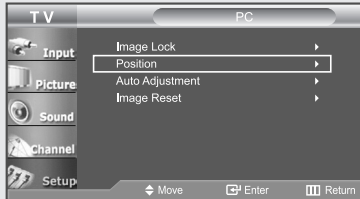

3

Press the **UP/DOWN**  buttons to adjust the V-Position.

Press the **LEFT/RIGHT**  buttons to adjust the H-Position.

Press the **EXIT** button to exit.

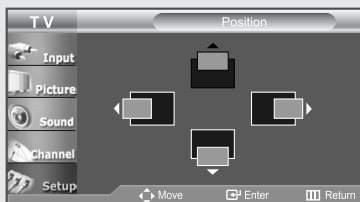
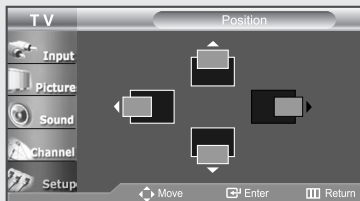

Initializing the Screen Position or Color Settings

Press the PC button under the remote's cover to select the PC mode.

1

Press the **MENU** button to display the menu.

Press the **UP/DOWN** buttons to select "Setup", then press the **ENTER** button.

Press the **UP/DOWN** buttons to select "PC", then press the **ENTER** button.



2

Press the **UP/DOWN** buttons to select "Image Reset", then press the **ENTER** button.

Press the **EXIT** button to exit.



Image reset is completed.

Return

Chapter 8

TIME SETTING

Setting the Clock

Setting the clock is necessary in order to use the various timer features of the TV. Also, you can check the time while watching the TV. (Just press the INFO button).

1

Press the **MENU** button to display the menu.

Press the **UP/DOWN** buttons to select "Setup", then press the **ENTER** button.

Press the **UP/DOWN** buttons to select "Time", then press the **ENTER** button.

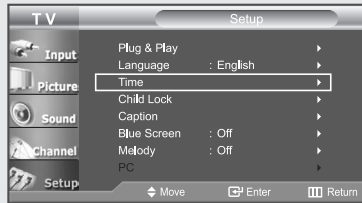

2

Press the **ENTER** button to select "Time", then press the **ENTER** button to select "Clock Set".

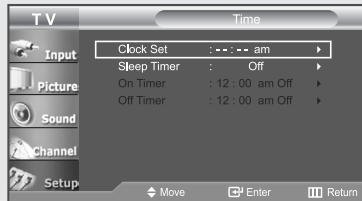

3

Press the **UP/DOWN** buttons repeatedly until the correct "Hour" appears.

After the hour is entered, press the **LEFT/RIGHT** buttons to select "Minute".

Press the **UP/DOWN** buttons until the correct "Minute" appears.

Press the **LEFT/RIGHT** buttons to select "am/pm" and adjust with the **UP/DOWN** buttons.

Press the **EXIT** button to exit.

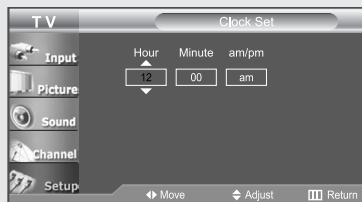

◀ You can also set the time using the number buttons on the remote.

Setting the Sleep Timer

Set the timer for the TV to turn off at the preset time automatically.

Sleep timer

1

Press the **MENU** button to display the menu.

Press the **UP/DOWN** buttons, then press the **ENTER** button.

Press the **UP/DOWN** buttons to select "Time", then press the **ENTER** button.



2

Press the **UP/DOWN** buttons to select "Sleep Timer", then press the **ENTER** button.

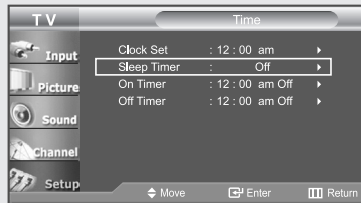

3

Press the **UP/DOWN** buttons repeatedly until the correct time appears.

Press the **EXIT** button to exit.



Alternate method:

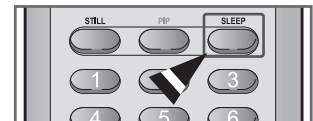

Press the **SLEEP** button on the remote. The number on the screen changes from Off • 30 • 60 • 90 • 120 • 150 • 180





Setting the On/Off Timer

1

Press the **MENU**  button to display the menu.



Press the **UP/DOWN**  buttons to select "Setup", then press the **ENTER**  button.

Press the **UP/DOWN**  buttons to select "Time", then press the **ENTER**  button.



◀ Before using the timer, you must set the TV's clock.

2

Press the **UP/DOWN**  buttons to select "On Timer", then press the **ENTER**  button.

Press the **UP/DOWN**  buttons repeatedly to select the appropriate "Hour".

Press the **LEFT/RIGHT**  buttons to select "Minute".

Press the **UP/DOWN**  buttons repeatedly to select the appropriate "Minute".

Set other items using the same method as above.

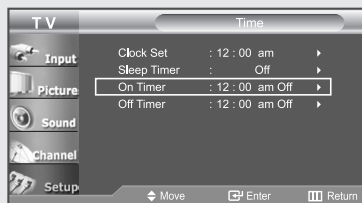
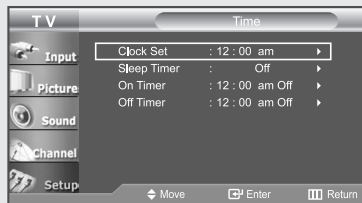

◀ When you set the hours, make sure the correct time of day (am or pm) appears to the right of the time.

◀ You can also set the time using the number buttons on the remote.

TIME SETTING

3

Press the **LEFT/RIGHT** ◀▶ buttons to select “Activation”. Press the **UP/DOWN** ▲▼ buttons to set the On Time “Yes”.

When finished, press the **ENTER** (↵) button.

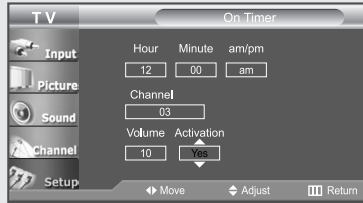

◀ To deactivate the “On Timer,” select “No” during this step.

◀ Repeatedly pressing the UP/DOWN ▲▼ buttons will alternate between “Yes” and “No”.

4

To set the Off time, press the **UP/DOWN** ▲▼ buttons to select “Off Timer”.

Press the **ENTER** (↵) button and set the hours and minutes.

(Follow the same procedure as in steps 2 and 3 above).

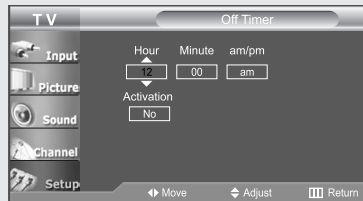
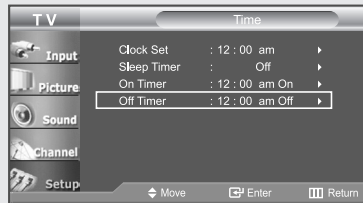

◀ You can also set the time using the number buttons on the remote.

5

When finished setting the timer, press the **EXIT** button to exit.

• Auto Power Off

When you set the timer on, your television will be turned off if you do not operate any controls for 3 hours after the TV has been turned on with the ‘Timer On’ function.

Chapter 9

FUNCTION DESCRIPTION

Selecting a Menu Language

1

Press the **MENU** button to display the menu.

Press the **UP/DOWN** buttons to select "Setup", then press the **ENTER** button.



2

Press the **UP/DOWN** buttons to select "Language". Press the **ENTER** button.



3

Press the **UP/DOWN** buttons to select "English", "Français", "Español", or "Portugués".

Press the **EXIT** button to exit.





Activating the Child Lock

This feature allows you to prevent unauthorized users, such as children, from watching unsuitable programmes by muting out video and audio. Child Lock cannot be released using front panel buttons. Only remote control can release the Child Lock setting, so keep the remote control away from children.

Note: This function does not work in PC mode.



1

Press the **MENU**  button to display the on-screen menu.

Press the **UP/DOWN**  buttons to select "Setup", then press the **ENTER**  button.



2

Press the **UP/DOWN**  buttons to select "Child Lock", then press the **ENTER**  button.

Press the **ENTER**  button.

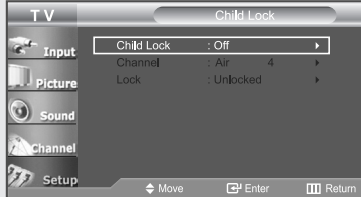

3

Press the **UP/DOWN**  buttons to select "On", then press the **ENTER**  button.



◀ Select "Off" to deactivate "Child Lock".

FUNCTION DESCRIPTION

4

Press the **UP/DOWN ▲▼** buttons to select "Channel", then press the **ENTER** button.

Press the **UP/DOWN ▲▼** buttons to select the channels to lock.

Press the **ENTER** button.



5

Press the **UP/DOWN ▲▼** buttons to select "Lock", then press the **ENTER** button.

Press the **UP/DOWN ▲▼** buttons to select "Locked" to lock the channels.

Press the **ENTER** button.



◀ Lock icon appears next to the locked channels.



◀ A blue screen is displayed when the "Child Lock" is activated.

6

Repeat step 4 and 5 to lock or unlock channels.

Press the **MENU** button to return to the previous menu or press the **EXIT** button to return to normal viewing.

Viewing Closed Captions

Your TV decodes and displays the closed captions that are broadcast with certain TV shows. These captions are usually subtitles for the hearing impaired or foreign-language translations. All VCRs record the closed caption signal from television programs, so home-recorded video tapes also provide closed captions. Most pre-recorded commercial video tapes provide closed captions as well. Check for the closed caption symbol in your television schedule and on the tape's packaging: **CC**.

1

Press the **MENU** button to display the menu.

Press the **UP/DOWN** buttons, then press the **ENTER** button.



2

Press the **UP/DOWN** buttons, then press the **ENTER** button.

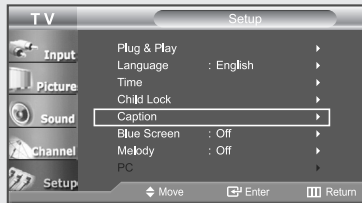

3

Press the **ENTER** button to select "Caption".

Press the **UP/DOWN** buttons to set the Caption "On", then press the **ENTER** button.

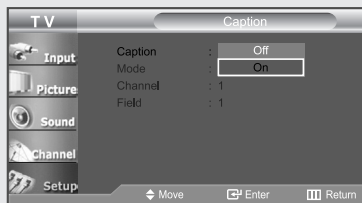

4

Depending on the particular broadcast, it might be necessary to alter the settings to "Channel" and "Field".

Alternate method:

Press the **CAPTION** button on the remote control.

◀ The Caption feature does not work with DVD or Set-top box signals.

Different channels and fields display different information: Field 2 carries additional information that supplements the information in Field 1. (For example, Channel 1 may have subtitles in English, while Channel 2 has subtitles in Spanish).



FUNCTION DESCRIPTION

5

Press the **UP/DOWN ▲▼** buttons to select “Mode”, then press the **ENTER** button.

Press the **UP/DOWN ▲▼** buttons to set “Caption” or “Text”, then press the **ENTER** button.



6

Press the **UP/DOWN ▲▼** buttons to select “Channel”, then press the **ENTER** button.

Press the **UP/DOWN ▲▼** buttons to select “1” or “2”, then press the **ENTER** button.

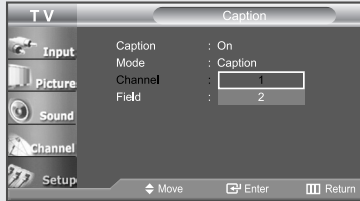
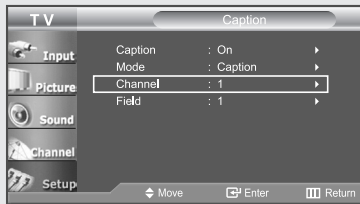

7

Press the **UP/DOWN ▲▼** buttons to select “Field”, then press the **ENTER** button.

Press the **UP/DOWN ▲▼** buttons to select “1” or “2”, then press the **ENTER** button.

Press the **EXIT** button to exit.

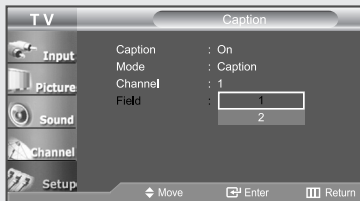
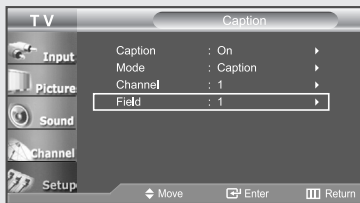



Setting the Blue Screen Mode

If no signal is being received or the signal is very weak, a blue screen automatically replaces the noisy picture background.

If you wish to continue viewing the poor picture, you must set the “Blue Screen” mode to “Off”.



1

Press the **MENU**  button to display the menu.

Press the **UP/DOWN**  buttons to select “Setup”, then press the **ENTER**  button.



2

Press the **UP/DOWN**  buttons to select “Blue Screen”, then press the **ENTER**  button.



3

Press the **UP/DOWN**  buttons to set Blue Screen “On”.

Press the **EXIT** button to exit.





Selecting the Melody

You can hear a melody sound when the television is powered on or off.



1

Press the **MENU**  button to display the menu.

Press the **UP/DOWN**  buttons to select "Setup", then press the **ENTER**  button.



2

Press the **UP/DOWN**  buttons to select "Melody", then press the **ENTER**  button.

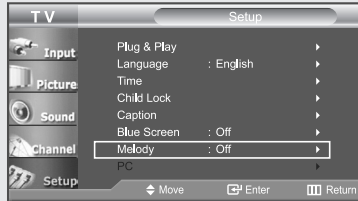

3

Press the **UP/DOWN**  buttons to select "On".

Press the **EXIT** button to exit.



Chapter 10

TROUBLESHOOTING

If the TV seems to have a problem, first try this list of possible problems and solutions. If none of these troubleshooting tips apply, call your nearest Samsung service center.

Identifying Problems

Problem	Possible Solution
Poor picture	Try another channel. Adjust the antenna. Check all wire connections.
Poor sound quality.	Try another channel. Adjust the antenna.
No picture or sound.	Try another channel. Press the SOURCE button. Make sure the TV is plugged in. Check the antenna connections.
No sound or sound is too low at maximum volume.	First, check the volume of units connected to your TV (digital broadcasting receiver, DTV, DVD, cable broadcasting receiver, VCR, etc.). Then, adjust the TV volume accordingly. Check if "Internal Mute" is off.
Picture rolls vertically.	Check all wire connections.
The TV operates erratically.	Unplug the TV for 30 seconds, then try operating it again.
Remote control malfunctions	Replace the remote control batteries. Clean the upper edge of the remote control (transmission window). Check the battery terminals.
"Check signal cable" message.	Ensure that the signal cable is firmly connected to the PC sources.
"Not Supported Mode" message.	Check the maximum resolution and the frequency of the Video Adapter. Compare these values with the data in the Display Modes.
The image is too light or too dark.	Adjust the Brightness and Contrast. Adjust the Fine tuning.
Horizontal bars appear to flicker, jitter or shimmer on the image.	Adjust the Coarse tuning and then adjust the Fine tuning.

TROUBLESHOOTING

Problem

Vertical bars appear to flicker, jitter or shimmer on the image.

Screen is black and power indicator light blinks steadily.

Image is not stable and may appear to vibrate when you have a computer connected to the PC input.

Image is not centered on the screen.

If a still image is displayed for an extended period of time, residual images or blurring may appear.

The TFT LCD panel uses a panel consisting of sub pixels (3,147,264) which require sophisticated technology to produce. However, there may be few bright or dark pixels on the screen. These pixels will have no impact on the performance of the product.

Possible Solution

Adjust the Coarse tuning and then adjust the Fine tuning.

On your computer check: Power, Signal Cable.
The TV is using its power management system.
Move the computer's mouse or press any key on the keyboard.

If the setting is not correct, use your computer utility program to change the display settings.

NOTE: Your TV supports multiscan display functions within the following frequency domain:

Horizontal frequency (kHz)	30~61
Vertical frequency (Hz)	60~75
Maximum refresh rate (at 60Hz)	1360 x 768

Adjust the horizontal and vertical position.
The screen position must be adjusted on the output source (i.e. STB) with a digital signal.

When you need to leave the monitor unused for an extended period of time, adjust the settings so that the monitor automatically goes into energy saving mode or activates the screen saver to display moving images.

Installing the stand

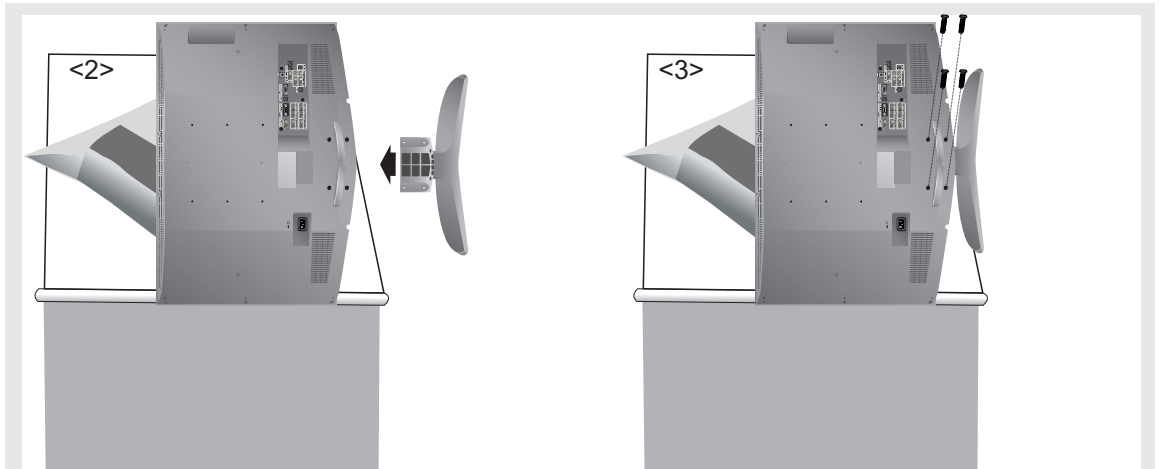

1. Place the TV faced down on a soft cloth or cushion on a table.
2. Attach the stand to the TV set as shown in the picture.
3. Use the four screws to tightly fix the stand.

Disconnecting the stand

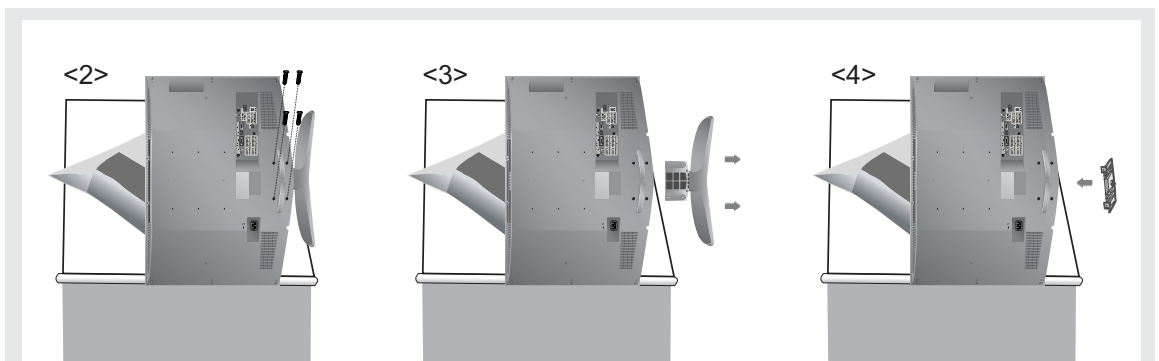

1. Place the TV faced down on a soft cloth or cushion on a table.
2. Remove four screws from the back of the TV.
3. Separate the stand from the TV.
4. Cover the bottom hole with a cap.

Installing the Wall Mount Kit

Note: This installation is to be used when attaching the wall mount to a concrete wall.
When attaching to other building materials, please contact your nearest dealer.

Components (Sold separately)

						
a Wall-Bracket	b Set-Bracket	c Screw: 8EA	d Wood Screw: 7EA	e Anchor: 7EA	f Screw: 3EA	g Installation Guide

How to assemble the Wall Mount Bracket

- 1 ① Mark the location on the wall where the hole will be drilled.
② Drill a hole of 35mm depth on the marked location.
③ Fix anchors **e** on each hole on the wall.
④ Connect wall-bracket **a** to the wall with wood screws **d** after fitting anchors **e** into the wall-bracket **a**.

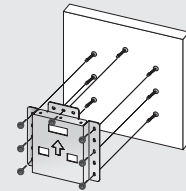

Note: If the bracket is not firmly fixed to the wall, LCD TV can fall off.

- 2 ① Turn the power off and unplug the power cord from the outlet.
② Place the TV faced down on a soft cloth or cushion on a table.
③ Attach the set-bracket **b** onto the rear side of the TV set and secure the screws **c**.

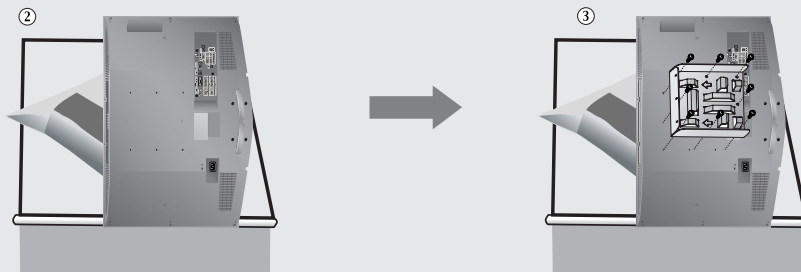

- 3 ① Insert three Hangers of the set-bracket **b** into the grooves of the wall-bracket **a**.
② Fix set-bracket **b** and wall-bracket **a** with screws **f**.

Note: Before installing the set on the wall, connect the cables to the set first.

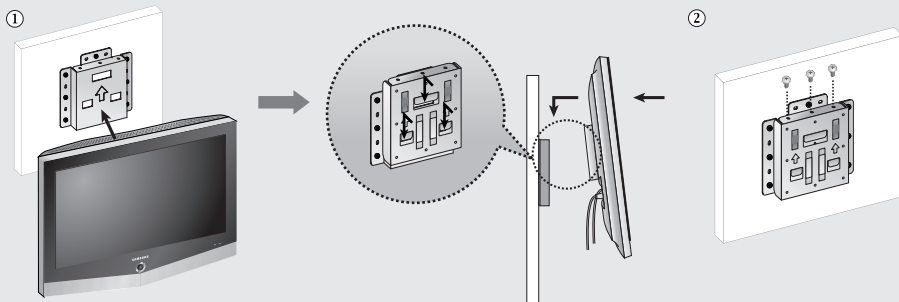

Using the Anti-Theft Kensington Lock

The Kensington lock is a device used to physically fix the system when using it in a public place.

The locking device has to be purchased separately. The appearance and locking method may differ from the illustration depending on the manufacturer. Please refer to the manual provided with the Kensington lock for proper use.

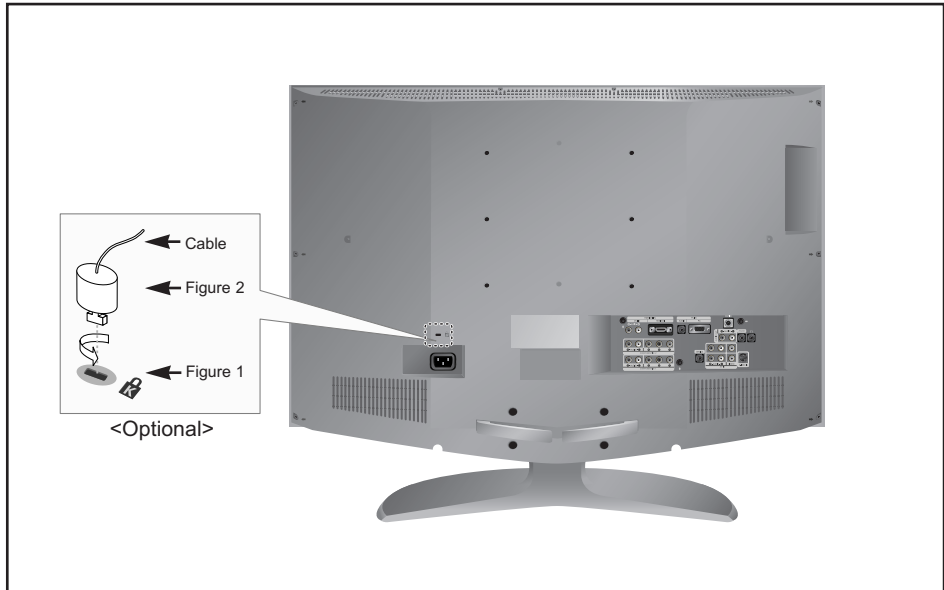

1. Insert the locking device into the Kensington slot on the LCD TV (Figure 1), and turn it in the locking direction (Figure 2).
2. Connect the Kensington lock cable.
3. Fix the Kensington lock to a desk or a heavy stationary object.

Using Your TV in Another Country

If you plan to take your TV with you to a foreign country, please be aware of the different television systems that are in use around the world. A TV designed for one system may not work properly with another system due to differences in the TV channel frequencies.

Specifications

Model Name	LN32R51B
Panel Size Display Size Type Pixel Pitch Viewing Angle Resolution	32" Diagonal (16:9) 27.47 (H) x 15.44 (V) inches (697.68 (H) x 392.26 (V) mm) a-si TFT active matrix 0.020 (H) x 0.020 (V) inches (0.511 (H) x 0.511 (V) mm) 170/170 (H/V) 1366 (H) x 768 (V)
Frequency Horizontal Vertical Display Color	30 ~ 61 kHz 60 ~ 75 Hz 16,777,216 colors
PC Resolution Maximum Mode Optimum Mode	1360 x 768 @ 60 Hz 1360 x 768 @ 60 Hz
Input Signal Sync. Video Signal	H/V Separate, TTL, P. or N. 0.7 Vp-p @ 75 ohm
TV Color System Sound System	NTSC STEREO
Video Color System Video System	NTSC CVBS, S-VHS
Component Video In Audio In	1.0 Vp-p @ 75 ohm 500 mVrms
Power Supply Input	AC 110~120 V, 60 Hz
Power Consumption Normal Power Saving	170 W < 1 W
Dimension (W x D x H) Body With stand	31.38 x 3.898 x 23.31 inches (797.0 x 99.0 x 592.0 mm) 31.38 x 9.80 x 25.62 inches (797.0 x 249.0 x 650.7 mm)

APPENDIX

Model Name	LN32R51B
Weight With Stand	39.02 lbs (17.7 kg)
Environmental Considerations Operating Temperature	50 °F to 104 °F (10 °C to 40 °C)
Operating Humidity	10 % to 80 %, non-condensing
Storage Temperature	-4 °F to 113 °F (-20 °C to 45 °C)
Storage Humidity	5 % to 95 %, non-condensing
Audio Characteristics Audio Input	RCA Jack (L, R), 0.5 Vrms (-9dB)
Audio Input (PC)	3.5 ø Stereo Jack, 0.5 Vrms (-9dB)
Headphone Output	Max. 10 mW Output (3.5 ø Stereo Jack, 32 Ω)
Frequency Response	RF: 80 Hz ~ 15 kHz (at -3dB) AV: 80 Hz ~ 20 kHz (at -3dB)

* Referring to Display Modes, page 74.

Display Modes

If the signal from the system equals the standard signal mode, the screen is adjusted automatically. If the signal from the system doesn't equal the standard signal mode, adjust the mode by referring to your video card user guide; otherwise there may be no video. For the display modes listed below, the screen image has been optimized during manufacture.

Mode	Resolution	Horizontal Frequency (kHz)	Vertical Frequency (Hz)	Pixel Clock Frequency (MHz)	Sync Polarity (H/V)
IBM	640 X 480	31.469	59.940	25.175	- / -
	720 X 400	31.469	70.087	28.322	- / +
VESA	640 X 480	37.861	72.809	31.500	- / -
	640 X 480	37.500	75.000	31.500	- / -
	800 X 600	37.879	60.317	40.000	+ / +
	800 X 600	48.077	72.188	50.000	+ / +
	800 X 600	46.875	75.000	49.500	+ / +
	1024 X 768	48.364	60.000	65.000	- / -
	1024 X 768	56.476	70.069	75.000	- / -
	1024 X 768	60.023	75.029	78.750	+ / +
	1360 X 768	47.712	60.015	85.800	+ / +

* The interlace mode is not supported.

* The set might operate abnormally if a non-standard video format is selected.

* DVI dose not support PC function.